

FUNDAMENTALS *of* Engineering Examination 2025

Information for Applicants



Professional Engineers Registration Examination Fundamentals of Engineering Examination 2025

Information for Applicants

Content	Page
1 Introduction	2
2 Eligibility To Sit For Examination.....	2
3 Fees	2
4 Dates Of Examination.....	3
5 Venue	3
6 Application	3
7 Structure Of Examination.....	3
8 Final Results and Notification.....	4
9 Examination Appeals	4
10 Review Courses	4
11 Refund Of Fees.....	4
12 Request for Accommodation.....	4

Annex A: FORMAT AND SYLLABUS, READING LISTS AND QUESTIONS FROM PAST YEAR PAPERS

I Fundamentals Of Engineering Examination (Civil).....	5
Recommended Reading List (Civil)	
Questions From Past Year Papers (Civil)	
II Fundamentals Of Engineering Examination (Electrical).....	24
Recommended Reading List (Electrical)	
Questions From Past Year Papers (Electrical)	
III Fundamentals Of Engineering Examination (Mechanical).....	40
Recommended Reading List (Mechanical)	
Questions From Past Year Papers (Mechanical)	
IV Fundamentals of Engineering Examination (Chemical)	52
Recommended Reading List (Chemical)	
Sample Questions (Chemical)	

Professional Engineers Registration Examination Fundamentals of Engineering Examination 2025 Information for Applicants

1 INTRODUCTION

The mission of the Professional Engineers Board is to safeguard life, property, and welfare of the public by setting and maintaining high standards for registering professional engineers and by regulating and advancing the practice of professional engineering.

The Professional Engineers Board registers professional engineers in the branches of civil, electrical, mechanical and chemical engineering. A person applying for registration as a professional engineer to the Professional Engineers Board is required to hold an approved degree or qualification listed in the [Professional Engineers \(Approved Qualifications\) Notification 2009](#) and acquired not less than 4 years of relevant practical experience. He is also required to sit and pass examinations prescribed by the Board. The applicant is required to sit and pass the Fundamentals of Engineering Examination and following that, to sit and pass the Practice of Professional Engineering Examination. In addition, the applicant is required to attend an interview.

The following sections set out the requirements and details for the Fundamentals of Engineering Examination 2025 while details on other application requirements are available on the PEB website at www.peb.gov.sg.

2 ELIGIBILITY TO SIT FOR EXAMINATION

The Fundamentals of Engineering Examination tests an applicant's knowledge of fundamental engineering subjects in civil, electrical, mechanical or chemical engineering. A person may apply to sit for the Fundamentals of Engineering Examination if he is undertaking a full time undergraduate engineering degree programme of not less than 4 years, or an equivalent programme approved by the Board, and is in his final year of study or after he has obtained an approved degree or qualification listed in the [Professional Engineers \(Approved Qualifications\) Notification 2009](#) or has proper and recognised academic qualifications in engineering accepted by the Board.

3 FEES

The fees for an application to sit for the Fundamentals of Engineering Examination is \$350.

4 DATES OF EXAMINATION

The dates for the Fundamentals of Engineering Examination 2025 are:

- a) Electrical Engineering – 2 January 2025
- b) Mechanical Engineering – 2 January 2025
- c) Chemical Engineering – 3 January 2025
- d) Civil Engineering – 3 January 2025

5 VENUE

Details of the venue would be given to successful applicants at a later date.

6 APPLICATION

Application and payment shall be made online at PEB website (<https://www.peb.gov.sg>) no later than 30 Sep 2024. For submission of required documents specified in the checklist, please send email to registrar@peb.gov.sg for an appointment within 1 week from application made online. Please note that submission is strictly by appointments only and that late submissions would not be accepted. Applicants are advised to send in their applications early to allow time for processing. They would be informed of the status of their applications and other details by post at least two weeks before the examinations.

7 STRUCTURE OF EXAMINATION

A summary of the structure of the Fundamentals of Engineering Examination is shown in the table below. The examination is 'open book' and further details are given in [**Annex A: Format and Syllabus, Reading Lists and Sample Questions / Questions From Past Year Papers.**](#)

Subjects	Time Allocated	Format
<u>FEE Part 1</u> Core engineering subjects in civil/mechanical/electrical/chemical engineering	*3 hours & 10 mins (9.00am – 12.10pm)	<ul style="list-style-type: none"> • 40 Multiple Choice Questions (MCQ)
<u>FEE Part 2</u> Core/Elective subjects in civil/electrical/mechanical/chemical engineering	*3 hours & 10 minutes (2.00pm – 5.10pm)	<ul style="list-style-type: none"> • Answer 5 out of 9 questions (civil) • Answer 5 out of 7 questions (electrical, mechanical, chemical)

* includes 10 minutes for reading the exam questions, etc.

For FEE (Civil) 2025, only answers based on Eurocodes and the relevant Singapore Annexes will be accepted. For transportation-related questions, AASHTO code is acceptable. Answers based on other codes and standards will not be accepted.

8 FINAL RESULTS AND NOTIFICATION

Examination results will be given to candidates on a Pass/Fail basis. No examination scores or marks will be given to candidates. Examination results will be mailed to the candidates around mid-April after the examination.

9 EXAMINATION APPEALS

A candidate who has failed the examination may submit a written appeal to review his performance. The appeal is to be received by PEB within 2 weeks after date of results and late appeals would not be considered. The result of the appeal/review will be sent by written mail to the appeal candidate. The appeal candidate would not be able to review his examination paper.

10 REVIEW COURSES

The Board does not endorse any review courses or materials provided as study aides.

11 REFUND OF FEES

Where an applicant who has been accepted is unable to sit for the examination subsequently, the Board may, at its discretion, refund \$100 to the applicant if the applicant submits a medical certificate by mail within 2 weeks after the examination. There will be no refund if the applicant sends a scanned copy of medical certificate via email.

12 REQUEST FOR ACCOMODATION

A candidate who has disabilities may submit a written request for accommodation. The request is to be received by PEB not later than 6 weeks before the date of examination and late request would not be considered. PEB's decision will be conveyed to the applicant by written mail not later than one week before the examination date.

Annex A: FORMAT AND SYLLABUS, READING LISTS AND QUESTIONS FROM PAST YEAR PAPERS

I Fundamentals Of Engineering Examination (Civil)

The examination will focus on testing the fundamentals of civil engineering. The 6-hour examination will comprise two parts. Part 1 catering for breadth, will comprise questions on core civil engineering subjects, typical of courses covered during the 1st and 2nd year of a 4-year civil engineering undergraduate course. Part 2 catering for depth, will comprise more core and elective civil engineering courses covered during the 3rd and 4th year of a 4-year civil engineering undergraduate course.

For FEE (Civil) 2025, only answers based on Eurocodes and the relevant Singapore Annexes will be accepted. For transportation-related questions, AASHTO code is acceptable. Answers based on other codes and standards will not be accepted.

Format

- **FEE Part 1 (Civil) (3 hours & 10 mins) – 40 MCQ questions**
 - CE 101 Mechanics of Materials
 - CE 102 Structural Mechanics
 - CE 103 Structural Analysis
 - CE 104 Soil Mechanics
 - CE 105 Fluid Mechanics

- **FEE Part 2 (Civil) (3 hours & 10 mins) – 5 out of 9 questions**
 - CE 201 Reinforced and Prestressed Concrete Structures (2 Qs)
 - CE 202 Steel Structures (2 Qs)
 - CE 203 Geotechnical Engineering (2 Qs)
 - CE 204 Transportation (1 Q)
 - CE 205 Hydraulics and Hydrology (1 Q)
 - CE 206 Environmental Engineering (1 Q)

Syllabus

- **CE 101 Mechanics of Materials**
 - **Mechanics of Materials**
Strength, stiffness and deformability; Stress-strain relations; ductility and brittle fracture; time-dependent properties; creep, creep rupture; relaxation; cyclic load behaviour.

-
- **Concrete Technology**
Concrete-making materials, properties of fresh and hardened concrete, mixing, placing, and curing, mix design, destructive and non-destructive tests, quality control, durability, and special concrete.
 - **Steel**
Basic metallurgy, mechanical properties and applications, welding technology and corrosion.
 - **CE 102 Structural Mechanics**
 - **Structural Mechanics**
Statics and kinetics of particles, equilibrium of rigid bodies, kinematics and plane motion of rigid bodies, analysis of simple trusses and beams, analysis of structural members subjected to tension, compression, torsion, and bending, including such fundamental concepts as stress, strain, and elastic behaviour. Bar forces in compound and complex trusses. Bending moment, shear and axial forces of beams and frames.
 - **CE 103 Structural Analysis**
 - **Structural Analysis**
Displacements of elastic determinate structures: principle of virtual work and energy theorems. Analysis of indeterminate structures. Deformation of indeterminate structures and influence line method. Displacement techniques using slope-deflection and moment distribution methods. Plastic theory and analysis. Theory and applications of modern structural analysis. Concepts of equilibrium, compatibility and force-displacement relationships. Direct stiffness method. Matrix formulation of trusses, beams and frames. Stability concepts and elastic stability analysis of framed structures.
 - **CE 104 Soil Mechanics**
 - Basic geology, unified soil classification system, mechanical properties, effective stress principle, shear strength, compressibility, and seepage and consolidation; Mohr-Coulomb failure criterion (drained and undrained), settlement calculations, rate of consolidation using classical Terzaghi theory.
 - **CE 105 Fluid Mechanics**
 - **Fluid Statics**
Fluid properties; hydrostatic pressure and thrust; buoyancy; stability of floating bodies.
-

-
- **Fluid Motion**
Continuity equations; Bernoulli's equation; linear momentum equation.
 - **Similitude**
Dimensional analysis; design of hydraulic models.
 - **CE 201 Reinforced and Prestressed Concrete Structures**
 - **RC Design**
Basic structural members and structural systems. Loads and load effects. Section analysis and design for bending. Design for shear, torsion and bond. Corbels. Serviceability and durability requirements. Design of short and slender columns. Design of slab systems. Concentrated loads on slabs. Design of foundations. Retaining walls. Reinforced concrete detailing.
 - **Prestressed Concrete Design**
Basic concepts of prestressing. Materials and prestressing systems. Prestressed losses and time dependent deformation. Behaviour and design of members subject to flexure, shear and combined axial and bending action.
 - **CE 202 Steel Structures**
 - **Steel Design**
Limit state design. Material properties and structural responses. Local buckling and section classifications. Design of fully restrained beams. Shear buckling and design of plate girder. Web bearing and buckling. Design of web stiffeners. Lateral-torsional buckling and design of laterally unrestrained beams. Tension and compression members. Axially loaded members with end moments. Design of steel connections. Plastic design of portal frames. Continuous multi-storey frames.
 - **CE 203 Geotechnical Engineering**
 - **Slope Stability and Earth Retaining Structures**
Introduction to slope stability and earth retaining structures; slopes and embankments; earth pressure and retaining structures; deep excavations; calculation of active and passive earth pressures; design considerations pertaining to deep excavations.
 - **Foundation Engineering**
Site investigation and interpretation of soil reports; shallow foundations and deep foundations; selection of appropriate foundation type; capacity and settlement requirements.

- **CE 204 Transportation**
 - **Transportation Engineering**
Transportation systems, planning and management; geometric design of roads and intersections; design of flexible and rigid pavements.
 - **Traffic Engineering**
Traffic flow studies; traffic data analysis; traffic management; highway and intersection capacity; traffic signal control. Parking.

- **CE 205 Hydraulics and Hydrology**
 - **Hydraulics**
Friction and minor losses in pipe flow; pipe and pump systems; pipe network analysis; open channel flow; uniform flow, Manning's equation; critical flow; energy and momentum principles; hydraulic jumps; gradually varied flows, backwater computation.
 - **Hydrology**
Processes in the hydrologic cycle: basic meteorology, rainfall precipitation, evaporation and transpiration, infiltration, sub-surface flow, surface runoff, streamflow measurement and hydrograph analysis; unit hydrograph principles and applications; frequency analysis of rainfall or flood data; reservoir and channel flood routing; urban storm drainage design, flood peak estimation.

- **CE 206 Environmental Engineering**
 - **Environmental Engineering**
Basic physical, chemical and biological water quality parameters; physical, chemical, and biological processes for water and wastewater treatment; water treatment principles and design; water distribution systems; wastewater collection and pumping systems; wastewater treatment design; pretreatment, primary, secondary, tertiary treatment, and anaerobic digestion.

Recommended Reading List for Civil Engineering

FEE Part 1 (Civil)

CE101 Mechanics of Materials

- 1) Hibbeler, R. C., "Mechanics of Materials" 9th Edition SI units, 2014.

CE120 Structural Mechanics

- 1) West, H. H. and Geshwinder, L. F. "Fundamentals of Structural Analysis" 2nd Edition, John Wiley and Sons, Inc, 2002.

CE103 Structural Analysis

- 1) West, H. H. and Geshwinder, L. F. "Fundamentals of Structural Analysis" 2nd Edition, John Wiley and Sons, Inc, 2002.

CE104 Soil Mechanics

- 1) Knappett, J.A. and Craig, R.F., "Craig's Soil Mechanics" 9th edition, CRC Press. 2019.

CE105 Fluid Mechanics

- 1) Finnemore, E.J., and Franzini. J.B. "Fluid Mechanics with Engineering Applications." 10th ed. Boston: McGraw Hill. 2002.
- 2) Young, D.F., Munson, B., Okiishi T.H. "A Brief Introduction to Fluid Mechanics", John Wiley and Sons, 3rd edition, 2004.

FEE Part 2 (Civil)

CE201 Reinforced and Prestressed Concrete Structures

- 1) E. O'Brien, A. Dixon and E. Sheils, "Reinforced and Prestressed Concrete Design to EC2: The Complete Process" 2nd Edition, Spon Press, 2013.
- 2) P. Bhatt, T.J. MacGinley and B.S. Choo, "Reinforced Concrete Design to Eurocodes – Design Theory & Examples" 4th Edition, CRC Press Taylor& Francis Group, 2014.

CE202 Steel Structures

- 1) Gardner L and Nethercot D, Designers' guide to Eurocode 3: Design of Steel Buildings, EN 1993-1-1, -1-3 and -1-8, 2nd Edition, Thomas Telford, 2011.
- 2) Steel building design: Concise Eurocodes, Steel Construction Institute (SCI) Publication P362, 2009.
- 3) Steel Building Design: Worked Examples – Open Sections, Steel Construction Institute (SCI) Publication P364, 2009.
- 4) Martin, L. and Purkiss, J., "Structural Design of Steelwork to EN 1993 and EN 1994", 3rd edition, Butterworth-Heinemann, UK, 2008.

CE203 Geotechnical Engineering

- 1) J. A. Knappett, and R. F. Craig, "Craig's Soil Mechanics" 9th Edition, CRC Press. 2019.
- 2) D. P. Coduto, M. R. Yeung, and W. A. Kitch, "Geotechnical Engineering: Principles and Practices", 2nd edition, Pearson, 2011.
- 3) Michael Tomlinson and John Woodward, "Pile Design and Construction Practice", 6th Edition, CRC Press, 2014.

CE204 Transportation

- 1) Mannering F. L. and Washburn, S. S. "Principles of Highway Engineering and Traffic Analysis" 7th Edition, Wiley, 2020.
- 2) Garber N. and Hoel, L. "Traffic and Highway Engineering" 4th Edition, Cengage Learning, 2010.
- 3) Papagiannakis, A.T. and Masad, E.A. "Pavement Design and Materials", Wiley. 2012.

CE205 Hydraulics and Hydrology

- 1) Linsley, R. K. Kohler, M. A. and Paulhus, J. L. H. "Hydrology for Engineers", SI Edition, McGraw Hill Book Co. 1998.

- 2) Chow, V. T. Maidment, D.R., Mays, L. W., "Applied Hydrology", McGraw Hill Book Co, 1988.
- 3) Chadwick, A., Morfett, J., and Borthwick, M., "Hydraulics in Civil and Environmental Engineering", 4th Edition, Spon Press, 2004.

CE206 Environmental Engineering

- 1) Viessman, W. and Hammer, M.J. "Water Supply and Pollution Control", 7th Edition, Pearson Prentice Hall, 2004.

Questions From Past Year Papers for Fundamentals Of Engineering Examination Part 1 (Civil)

Questions from past year papers for Fundamentals Of Engineering Examination Part 1 (Civil) based on BS and EC Codes.

For FEE (Civil) 2025, only answers based on Eurocodes and the relevant Singapore Annexes will be accepted. Answers based on other codes and standards will not be accepted.

(Actual paper comprises 40 Multiple Choice Questions (MCQ) of 2.5 marks each. Answer all questions.)

1. A steel bar comprises three sections of three cross sections as shown in Fig. Q1. The diameters of parts AB, BC and CD are 25 mm, 15 mm and 35 mm respectively. The bar is subjected to an axial tensile force of 5 kN. If Young's modulus of steel is 200 kN/mm^2 , and the elongations of the three sections of the bars are Δ_1 , Δ_2 and Δ_3 respectively, calculate the ratio of the largest to the smallest of these three elongations.

- (a) 1.96
(b) 2.33
(c) 5.44
(d) 2.77

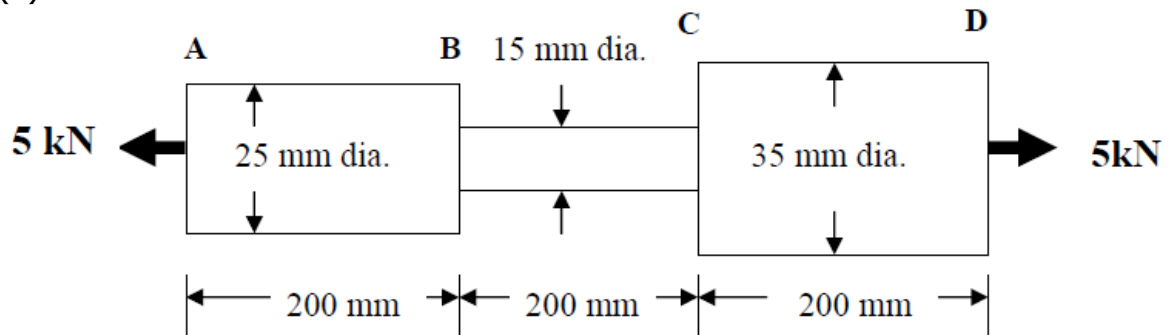

Fig.Q1

2. Three plane trusses are shown in Fig.Q2. The statical determinacy of the trusses, (1), (2) and (3) are respectively:
- (a) determinate, indeterminate, unstable
(b) determinate, determinate, unstable
(c) determinate, indeterminate, determinate
(d) indeterminate, indeterminate, determinate

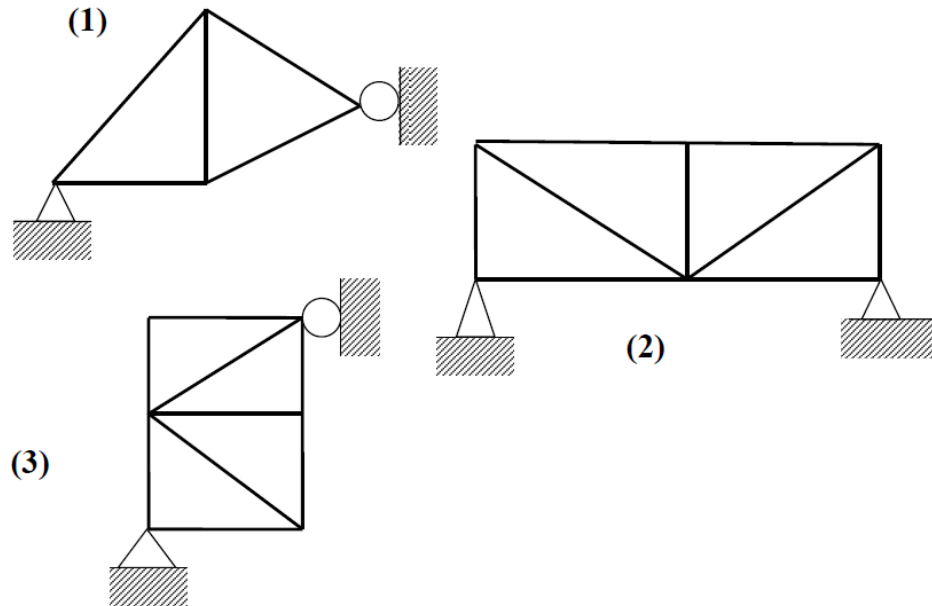

Fig.Q2

3. The static indeterminacy of the beams, (1), (2), (3) and (4) shown in Fig.Q3 are respectively:

- (a) 1, 4, 5, 1
- (b) 2, 4, 5, 2
- (c) 1, 4, 5, 2
- (d) 1, 5, 4, 1

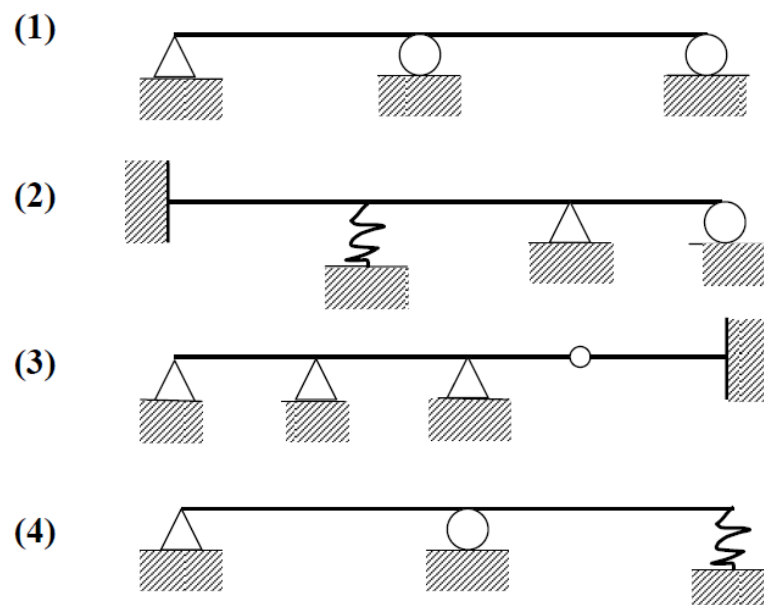

Fig.Q3

4. A reinforced concrete column shown in Fig.Q4 supports a load of 10 kN. The load is shared between the steel reinforcement and the concrete. The cross-sectional areas and Young's moduli are:
 $A_c = 1 \times 10^4 \text{ mm}^2$ and $E_c = 20 \text{ kN/mm}^2$
 $A_s = 200 \text{ mm}^2$ and $E_s = 210 \text{ kN/mm}^2$

What is the force carried by the steel reinforcement?

- (a) 1.96 kN
- (b) 2.74 kN
- (c) 2.96 kN
- (d) 1.74 kN

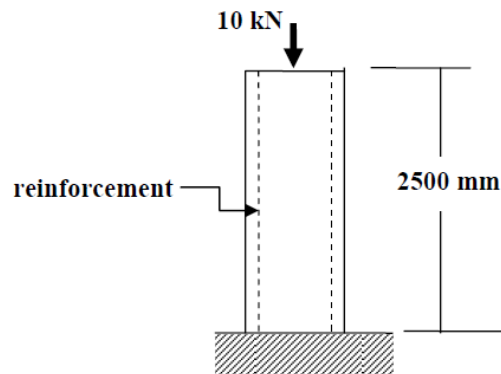

Fig.Q4

5. If seawater is used in place of potable water to cast OPC concrete, the effect is to
- 1. increase its strength;
 - 2. reduce its strength;
 - 3. retard setting;
 - 4. decrease its durability.

Of the above,

- (a) 1 and 3 are correct
- (b) 2 and 3 are correct
- (c) 2 and 4 are correct
- (d) 1 and 4 are correct

6. Find the position at which the maximum upward deflection for this beam with an overhang as shown in Fig.Q6 occurs.

- (a) $L/4$ from A
- (b) $L/\sqrt{3}$ from A
- (c) $L/2$ from A
- (d) $2L/\sqrt{3}$ from A

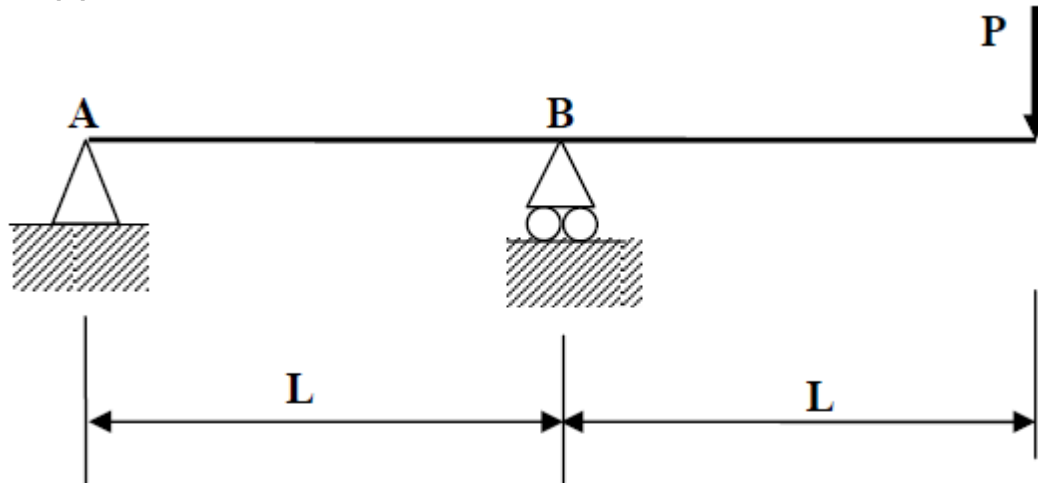
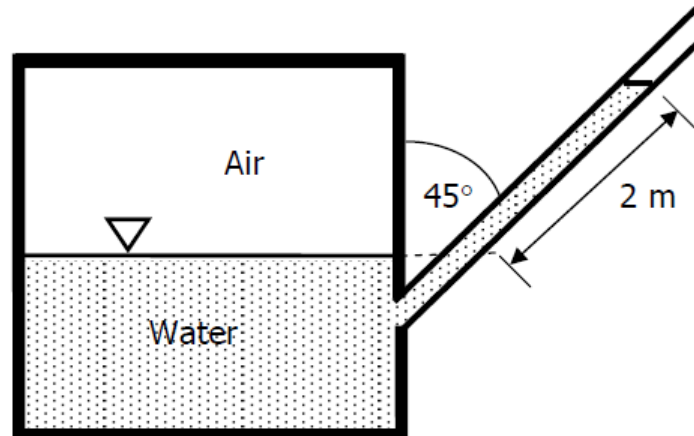

Fig.Q6

7. A river is 3m deep and the riverbed consists of a thick deposit of clay with a saturated unit weight of 20kN/m^3 . What is the effective stress of the clay layer at a depth of 3m below the riverbed level?
- (a) 30 kN/m^2
 - (b) 60 kN/m^2
 - (c) 90 kN/m^2
 - (d) 120 kN/m^2
8. During the site investigation for a deep foundation design, you discover in the borehole a layer of soft clay 5m deep where you had expected a hard stratum at the estimated depth of pile toe. Which of the following action would you take?
- (a) Bore an extra 5m deeper than the original plan
 - (b) Stop boring and move to the next borehole location
 - (c) Continue boring until stronger soil is found
 - (d) Abandon the site

9. In the figure below, what is the gauge pressure of air inside the closed container?



- (a) 19,620 N/m²
 (b) 13,873 N/m²
 (c) 16,991 N/m²
 (d) Cannot be determined
10. A 1:20 scale river model is designed based on Froude number similarity. What is the prototype flow velocity which corresponds to a model measured velocity of 0.5 m/s? Given Froude number $F_r = \frac{V}{\sqrt{gL}}$
- (a) 10 m/s
 (b) 158.1 m/s
 (c) 2.24 m/s
 (d) None of the above

Questions From Past Year Papers for Fundamentals Of Engineering Examination Part 2 (Civil)

Questions from past year papers for Fundamentals of Engineering Examination Part 2 (Civil) based on BS and EC codes.

(Note: For FEE (Civil) 2025, only answers based on Eurocodes and the relevant Singapore Annexes will be accepted. Answers based on other codes and standards will not be accepted.)

(Actual paper comprises 9 questions. Answer 5 questions)

Q1.

Figure Q1 shows the cross section of a T-shape column, subjected to axial load and bending moment about y-y axis.

With the following design data, calculate the maximum pure axial capacity, maximum bending moment capacity and construct N-M interaction diagram for the cross section.

Design data and assumptions:

Concrete strength: $f_{ck} = 45 \text{ N/mm}^2$

Yield strength of reinforcement bar: $f_{yk} = 500 \text{ N/mm}^2$

Density of reinforced concrete = 25 kN/m^3

Concrete cover to centre of rebar = 40 mm

Concrete ultimate strain, $\epsilon_{cu} = 0.0035$

Young modulus for steel reinforcement = $200,000 \text{ N/mm}^2$

For tension failure case that is required for the construction of N-M interaction diagram, you can assume that the neutral axis is 100 mm from extreme compression face.

Calculations shall be performed in accordance to relevant Eurocodes.

(20 marks)

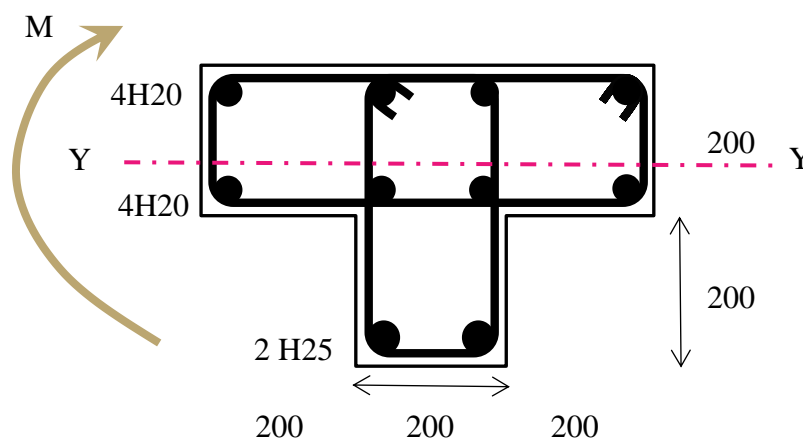

(Note: drawings are not drawn to scale, all dimensions in mm U.N.O.)

Figure Q1

Q2.

To facilitate excavation for a new underground MRT station, a steel strutting and waling system together with concrete diaphragm wall are to be used for its construction. The transverse design strut force to be transmitted to the concrete wall is 3500 kN as shown in Figure Q2.

- (a) Calculate the bearing and buckling resistances of the unstiffened web of the waler which is subjected to the transverse strut force. The sizes of the strut and waler as well as the strut-waler connection details are indicated clearly in the figure.

(10 marks)

- (b) Determine whether the unstiffened web of the waler is adequate to transfer the design strut force or not. Propose an effective strengthening scheme if it is inadequate. Detailed design of the strengthening scheme is not required.

(10 marks)

You may assume that the strut is not at the end or near the end of the waler. State clearly your other design assumptions, if any.

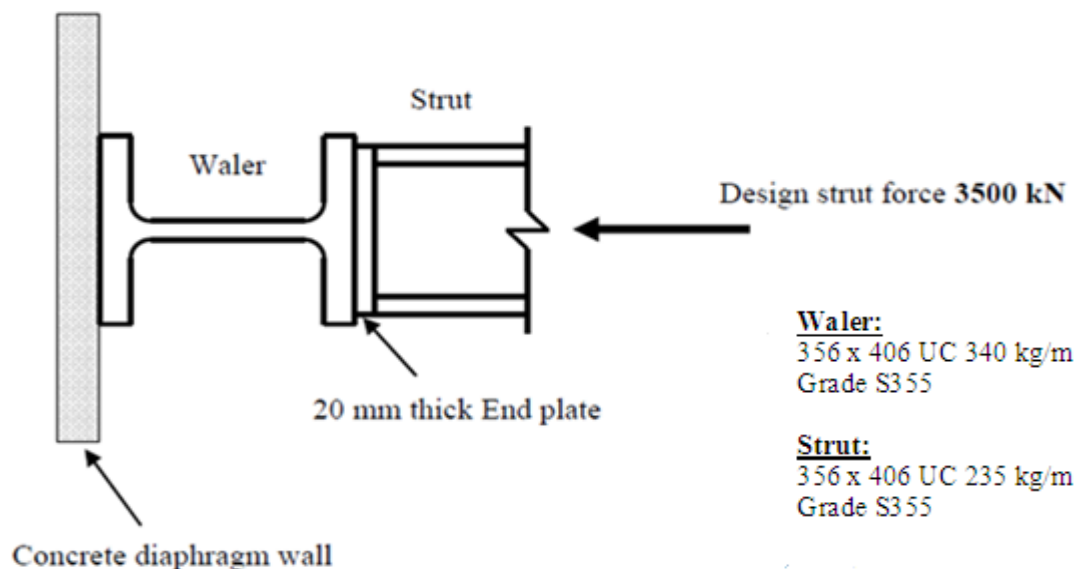

Figure Q2

Q3.

- (a) A rectangular short column of size 350 mm by 500 mm is required to resist an axial load of 3600 kN. What is the area of steel required? Provide a sketch showing the reinforcement details, including the links to be provided.

(8 marks)

- (b) Re-design the rectangular column in Part (a), of size 350 mm and 500 mm to resist an additional bending moment of 300 kNm. Provide a sketch showing the revised reinforcement details, including the links to be provided.

(12 marks)

Assume a clear cover of 30 mm to the links. Use $f_{ck} = 32 \text{ N/mm}^2$ and $f_{yk} = 500 \text{ N/mm}^2$. State clearly why the respective reinforcing bar sizes are chosen.

Design aids in the form of design charts or tables may be provided.

Q4.

- (a) A 0.8 m diameter bored pile (weight density = 25 kN/m^3) is to be formed in a clay site with the representative undrained shear strength (c_u) profile as shown in Figure Q4. The groundwater table is at the ground surface. Determine the ultimate axial load capacity of the pile under undrained condition if the embedment length of the pile is 20 m.

(14 marks)

- (b) If a 1 m thick sand fill is placed on the site, what additional load will the pile experience? Describe the effect of this load on the load carrying capacity of the pile and estimate the maximum possible magnitude of this load in the clay.

(6 marks)

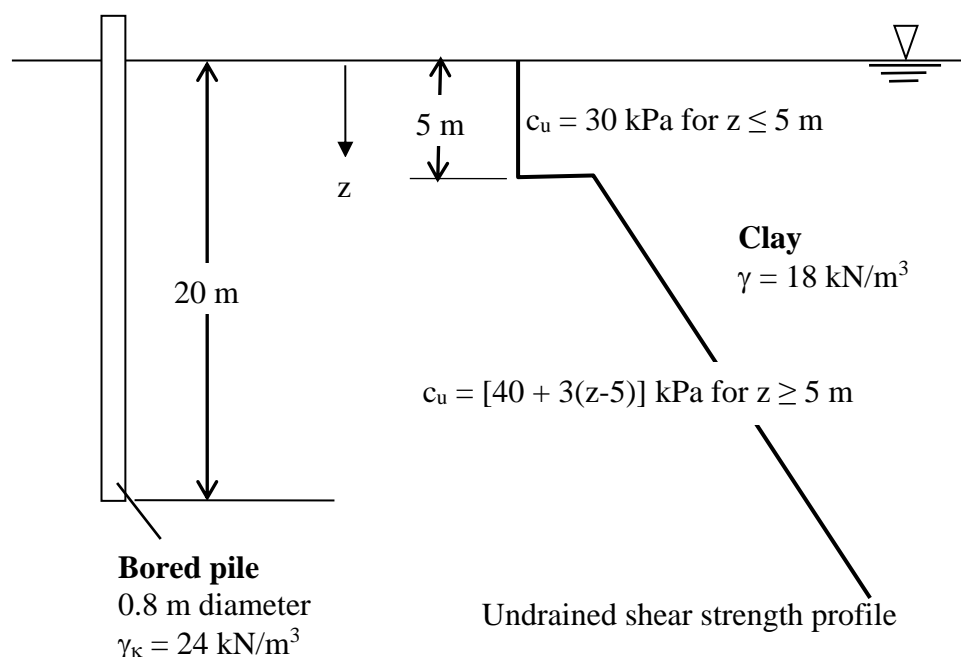
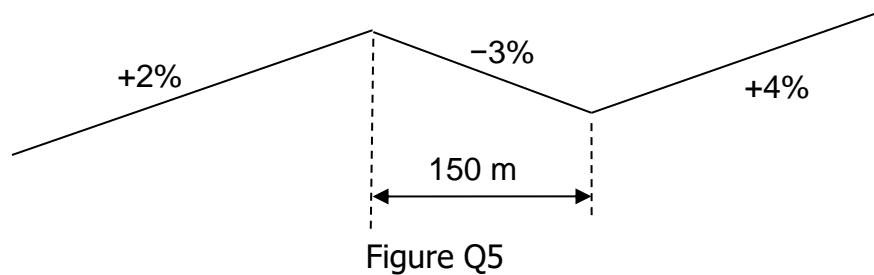

Figure Q4

Q5.

- (a) A pair of vertical curves are to connect a series of tangent grades for which the slopes are shown in Figure Q5. The middle section is 150 metres long.



The following information is provided for design calculation.

Driver reaction time: 2.5 seconds

Driver eye height: 1.050 metres

Tyre-pavement friction coefficient: 0.30

Object height for stopping: 0.150 metres

Road design speed: 70 km/h

- (i) The required minimum stopping sight distance for motorists is found to be 120.0 metres on the crest curve, and 122.7 metres on the sag curve. Show how the value for the minimum stopping sight distance is obtained for either the crest curve or the sag curve.
- (ii) Calculate the minimum length of the crest curve, and the sag curve, that satisfies the respective minimum stopping sight distance. Hence, show that the middle section is too short for the pair of vertical curves to be fully developed.

(10 marks)

- (b) A 3-layer flexible pavement is to be constructed using materials with properties given in the following table.

Material	Drainage coefficient ($m's$)	Layer coefficient ($a's$)	SN value above layer (from AASHTO charts)
Asphalt concrete	impermeable	0.45	not applicable
Granite aggregate	1.20	0.20	2.3
Sandy gravel	1.10	0.12	3.3
Roadbed soil	0.60	0.05	4.3

- (i) Compute the thickness of each layer in the flexible pavement.
- (ii) List several advantages of a flexible pavement design over that of a rigid pavement.

(10 marks)

LIST OF FORMULAE

Reaction Distance, d_r :

$$d_r = vt_r$$

Braking Distance, d_b :

$$d_b = \frac{v^2}{2g(f \pm G)}$$

Minimum Length (Crest Curve), L_{\min} :

$$L_{\min} = \begin{cases} \frac{AS^2}{200(\sqrt{h_1} + \sqrt{h_2})^2} & \text{When } S \leq L \\ 2S - \frac{200(\sqrt{h_1} + \sqrt{h_2})^2}{A} & \text{When } S > L \end{cases}$$

Minimum Length (Sag Curve), L_{\min} :

$$L_{\min} = \begin{cases} \frac{AS^2}{200[0.6 + S(\tan 1^\circ)]} = \frac{AS^2}{120 + 3.5S} & \text{When } S \leq L \\ 2S - \frac{200[0.6 + S(\tan 1^\circ)]}{A} = 2S - \frac{120 + 3.5S}{A} & \text{When } S > L \end{cases}$$

AASHTO Structural Number (SN) Equation:

$$SN = a_1D_1 + a_2D_2m_2 + a_3D_3m_3 + \dots$$

Q6.

A sluice gate is installed in a rectangular open channel with a width $B = 2$ m. The flow depth measured at a location (Section 1) immediately downstream of the sluice gate is 0.5 m, and its mean flow velocity is 4 m/s.

- (a) What is the flow rate, Q (m^3/s) in the channel under this flow condition?
(2 marks)
- (b) What is the specific energy, E_1 at Section 1 under this flow condition?
(3 marks)
- (c) What is critical specific energy, E_c under this flow condition?
(3 marks)
- (d) What is the flow regime (i.e., sub-critical, critical, or super-critical flow) at Section 1?
(2 marks)
- (e) A hydraulic jump occurs downstream of the sluice gate. The initial depth of the jump occurs at Section 1. What is the sequent depth, y_2 of the jump?
(5 marks)
- (f) If the Manning's coefficient n of the channel = 0.02, estimate the channel bed slope, S_o . State your assumption(s).
(5 marks)

Useful equations:

- (a) Specific energy, $E = y + \frac{V^2}{2g}$, where V = velocity, y = flow depth.
- (b) Critical specific energy, $E_c = 1.5 y_c$ for a rectangular channel.
- (c) Critical flow depth, $y_c = \sqrt[3]{\frac{q^2}{g}}$ for a rectangular channel, where q [m^2/s] = discharge per unit width = Q/B , Q = flow rate, B = channel width, g = gravitational acceleration.
- (d) Simple hydraulic jump equation for a rectangular channel is $y_2 = \frac{y_1}{2} \left(\sqrt{1 + 8 Fr_1^2} - 1 \right)$ where $Fr_1 = \frac{V_1}{\sqrt{gy_1}}$ = Froude number at the initial depth location, y_1 = initial depth, y_2 = sequent depth, V_1 = velocity at the initial depth location.
- (e) Manning's equation, $Q = \frac{1}{n} AR_h^{2/3} S_o^{1/2}$, where n = Manning's coefficient, S_o = channel bed slope, R_h = hydraulics radius (= A/P), A = flow area, P = wetted perimeter.

Q7.

(a) A primary clarifier with a surface area overflow rate of $55 \text{ m}^3/\text{m}^2\cdot\text{day}$ receives a wastewater from an equivalent population of 45,000 having a capita flow rate of 550 L/d and a per capita suspended solids (SS) of 32 g/d.

(i) Determine the clarifier **diameter** and **depth** based on a 2-hour hydraulic retention time.

(4 marks)

(ii) Determine the volume of primary sludge produced daily if 75% of the SS are removed by the clarification process. Assume that the sludge contains 1.5% SS, the sludge specific gravity is 1.005, and a water density of $1,000 \text{ kg}/\text{m}^3$.

(4 marks)

(b) An activated sludge process is used to treat a combined wastewater from two separate sources of seafood processing and raw sugar refining, respectively. The seafood processing produces a wastewater stream of $200 \text{ m}^3/\text{d}$ with 550 BOD_5/L , and the sugar refinery produces another wastewater stream of $320 \text{ m}^3/\text{d}$ with 650 BOD_5/L . The activated sludge reactor is operating at an organic loading rate of $4 \text{ kg BOD}_5/\text{m}^3\cdot\text{d}$.

(i) Calculate the **volume** of the reactor and the **hydraulic retention time** based on the combined wastewater flow and BOD_5 concentration.

(6 marks)

(ii) For a Food/Microorganism ratio of $0.6 \text{ kg BOD}_5/\text{kg MLVSS}\cdot\text{d}$, what MLVSS concentration should be maintained in the aeration tank?

(3 marks)

(iii) Estimate the mean cell residence time, assuming an effluent volatile solids concentration of $20 \text{ mg}/\text{L}$ and the daily amount of waste sludge is 95 m^3 that contains 1% of volatile solids.

(3 marks)

Given:

Hydraulic retention time = BOD_5 concentration/ Organic loading rate

$$F/M = (Q \times S) / (V_r \times MLVSS)$$

$$\text{Mean cell residence time, } \theta_c = V_r \times MLVSS / (Q_e \times X_e + Q_w \times X_r)$$

Where:

F/M is food to Microorganism ratio

Q is Flow rate

S is organic concentration BOD_5

V_r is volume of reactor

θ_c is Mean cell residence time

MLVSS is Mixed Liquor Volatile Suspended Solid

Q_e is effluent flow rate m^3/d

X_e is effluent volatile solids

Q_w is waste sludge flow rate m^3/d

X_r is volatile solid in sludge

II **Fundamentals Of Engineering Examination (Electrical)**

The examination will focus on testing the fundamentals of electrical power engineering. The 6-hour examination will comprise two parts.

Format

- **FEE Part 1 (Electrical) (3 hours & 10 mins) - 40 MCQ questions**
 - EE 101 Principles of Power Engineering
- **FEE Part 2 (Electrical) (3 hours & 10 mins) - 5 out of 7 questions**
 - EE 201 Power System Analysis and Utilization

Syllabus

- **EE 101 Principles of Power Engineering**
 - **Three-phase Circuits and Systems**

Review of single-phase circuits. Three-phase voltage generation. Phasor diagrams. Wye and delta connections. Balanced / unbalanced three-phase loads. Active, reactive and apparent power. Power measurements. Power factor correction.
 - **Magnetism and Magnetic Circuits**

Magnetic fields. Magnetic materials and magnetization curves. Magnetic equivalent circuits. Electromagnetic induction. Sinusoidal excitation. Magnetic losses.
 - **Transformers**

Ideal transformer. Equivalent circuits. Phasor diagrams. Determination of parameters. Performance evaluation. Autotransformers. Three-phase transformers. Phase shift transformers.
 - **AC and DC Machines**

DC Machines: operating principle, voltage and torque equations, classification, torque-speed characteristics, losses and efficiency. Three-phase induction motors: operating principle, assist starting, starting methods, equivalent circuit, torque-speed characteristics, losses and efficiency. Brushless DC motor, PMSM.
 - **Power Electronics**

Introduction to power conversion. Harmonics. AC to DC conversion. DC to DC conversion. DC to AC conversion. DC servo motor drive systems. AC variable-speed induction motor drive systems. Permanent magnet and stepping motor drive systems. Power Electronics devices.

-
- **Fundamental of Power Systems**
Energy sources. Per unit system. Power system components and representation: synchronous generators, transmission lines and cables. Load representations. Power transfer. Power system stability.
 - **Power Flow Modelling**
System components modelling. Formulation of power flow equations. Methods of power flow solution.
 - **Applications of High-voltage Engineering**
Insulation materials and properties. Electrical breakdown in gases, liquids, and solids. High voltage cables. High voltage switchgear. Lightning and surge protection. Acceptance and routine tests on apparatus.
 - **EE 201 Power System Analysis and Utilizations**
 - **Power System Operation and Control**
Governor control systems. Active power and frequency control. Production and absorption of reactive power. Methods of voltage control. Reactive power and voltage control. Application to transmission and distribution systems.
 - **Analysis of Symmetrical and Unsymmetrical Faults**
Three-phase faults and fault level calculations. Symmetrical components. Sequence impedances and sequence networks. Unsymmetrical faults.
 - **Electric Power Distribution Systems**
Distribution system configurations. Primary and secondary distribution. Ring, radial and inter-connected systems. Distribution substation layout. Planning criteria and network design.
 - **Building Services Engineering**
Estimation of power demand. Conductor sizing and correction factors. Earthing system, earth fault and touch voltage.
 - **General Protection Principles**
Basic protection principles. Instrument transformers. Coordination of IDMTL and DTL overcurrent and earth protection for distribution systems. Differential protection of feeders and transformers.
 - **Electric Drives**
Controlled converter fed DC motor drives. Chopper circuit configurations in DC drives. Inverter fed AC drives. Variable voltage and variable frequency operation. Power quality and harmonics.

- **Sustainable Energy Technology and Applications**

Distributed energy resources. Sustainable energy technology. Solar PV technology. PV system design. Grid-tied PV systems. Energy conversion and energy storage system.

Recommended Reading List for Electrical Engineering

FEE Part 1 (Electrical)

EE 101 Principles of Power Engineering

- 1) Guru Bhag S and Hiziroglu Huseyin R, Electric Machinery and Transformers, 3rd Edition, Oxford University Press, 2001.
- 2) Sen Paresh Chandra, Principles of Electric Machines and Power Electronics, Hoboken, NJ: John Wiley & Sons, 2014.
- 3) Chapman Stephen J, Electric Machinery and Power System Fundamentals, 1st Edition, McGraw-Hill, 2002.
- 4) Wildi Theodore, Electrical Machines, Drives and Power Systems, 6th Edition, Pearson/Prentice-Hall, 2006

FEE Part 2 (Electrical)

EE 201 Power System Analysis and Utilizations

- 1) Grainger John J and Stevenson William D, Power System Analysis, McGraw-Hill, 1994.
- 2) Bergen Arthur R and Vittal Vijay, Power System Analysis, 2nd Edition, Prentice-Hall, 2000.
- 3) Weedy B M and Cory B J, Jenkins N, Ekanayake J B, Strbac G, Electric Power Systems, 5th Edition, John Wiley, 2012.
- 4) Pabla A S, Electric Power Distribution, 6th Edition, McGraw-Hill, 2011.
- 5) Code of Practice for Electrical Installations, (Singapore Standards, CP5 1998), Singapore Productivity and Standards Board, 1998.
- 6) Lakervi E and Holmes E J, Electricity Distribution Network Design, (IEE Power Engineering Series), 2nd Edition, London: Peter Peregrinus, 2003.
- 7) Paithankar Y G, Transmission Network Protection: Theory and Practice, Marcel Dekker, 1998.
- 8) Gers Juan M and Holmes Edward J, Protection of Electricity Distribution Networks, Institution of Electrical Engineers, 2011.
- 9) Naidu M S and Kamaraju V, High Voltage Engineering, McGraw-Hill, 2013.
- 10) Ram Badri and Vishwakarma D N, Power System Protection and Switchgear, McGraw-Hill, 2011.
- 11) Teo Cheng Yu, Principles and Design of Low Voltage Systems, Revised 2nd Edition, seventh print, Byte Power Publications, 2012.
- 12) Blackburn J Lewis, Protective Relaying: Principles and Applications, 4th Edition, CRC Press, 2014.

Questions From Past Year Papers for Fundamentals Of Engineering Examination Part 1 (Electrical)

(Actual paper comprises 40 Multiple Choice Questions (MCQ) of 2.5 marks each. Answer all questions.)

1. A three-phase generator supplies 3.6 kVA at a power factor of 0.85 lagging. If 2500 W is delivered to the load and line losses are 80 W per phase, what are the losses in the generator?

(a) 480 W
(b) 320 W
(c) 860 W
(d) 240 W
2. A factory uses 3-phase, 400 V commercial power. The principal users of power are an induction motor operating at 300 kW with a power factor of 0.65 lagging and an injection moulding machine operating at 600 kVA with a power factor of 0.63 lagging. What is the power factor for the factory?

(a) 0.61
(b) 0.78
(c) 0.59
(d) 0.64
3. A three-phase Y-connected generator with a phase voltage of 500 V and a frequency of 50 Hz is connected through power lines to a balanced delta-connected load that consumes 400 kW of power at 0.77 pf lagging. What is the phase current of the load?

(a) 154 A
(b) 266 A
(c) 200 A
(d) 346 A
4. 1-phase 230 V 50 Hz supply is connected to the coil of Figure Q4. Use the following parameters of the core and find the current in the coil.

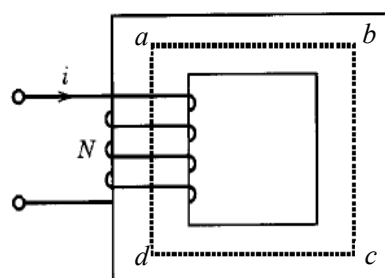

Length of abcd = 80 cm

Cross sectional area of core = 20 cm^2

$N = 180$ turns

Permeability = $3.1415 \times 10^{-3} \text{ H/m}$

- (a) $4.07 \sin(\omega t)$ A
 (b) $0.407 \sin(\omega t)$ A
 (c) $3.89 \sin(\omega t)$ A
 (d) $0.389 \sin(\omega t)$ A
5. With reference to Figure Q5, determine the V_{rms} induced in the coil if a 50 Hz ac current of $0.3 \sin(\omega t)$ A is flowing through the coil. Inductance L is given as 0.24 H..

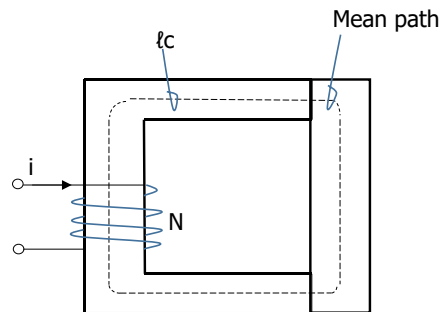

Figure Q5

- (a) 22.6 V
 (b) 16 V
 (c) 11.3
 (d) 8 V
6. What is the flux density in a round iron core if its diameter is 2 cm and flux Φ is 7×10^{-5} Wb.
- (a) 0.056 T
 (b) 2.23×10^{-5} T
 (c) 3.5×10^{-5} T
 (d) 0.223 T
7. A 1,000 KVA transformer has 2,500 watts iron loss, and 11,000 watts copper loss at full load. The power factor is 0.85 lagging. Calculate the all-day efficiency of the transformer at daily load cycle of 14 hours half load and 10 hours full load.
- (a) 97.32%
 (b) 98.58%
 (c) 99.20%
 (d) 99.75%
8. Two transformers, T1 and T2, are connected in parallel. Transformer T1 is rated at 1,500 kVA with 5% impedance, and transformer T2 is rated at 2,000 kVA with 6% impedance. The transformers have the same turns ratio, and are

connected to a common 3,000 kVA load. What is the loading on each transformer?

- (a) $S_{T1} = 1,256$ kVA, $S_{T2} = 1,744$ kVA
- (b) $S_{T1} = 1,364$ kVA, $S_{T2} = 1,636$ kVA
- (c) $S_{T1} = 1,421$ kVA, $S_{T2} = 1,579$ kVA
- (d) $S_{T1} = 1,714$ kVA, $S_{T2} = 1,286$ kVA

9. The copper losses of a 1,000 kVA, 22/0.4 kV, 3 phase, delta-star connected transformer are 1.5 kW and 0.6 kW on high voltage and low voltage side respectively. Find the total resistance in ohms per phase at 22kV side (r_1) and 400V side (r_2).

- (a) $r_1 = 0.726$, $r_2 = 0.000096$
- (b) $r_1 = 2.178$, $r_2 = 0.000096$
- (c) $r_1 = 6.534$, $r_2 = 0.000288$
- (d) $r_1 = 2.178$, $r_2 = 0.000288$

10. The field current of a separately excited DC motor is increased by 10 %. What is the expected change in motor speed?

- (a) No change
- (b) Increase by about 10 %
- (c) Decrease by about 10 %
- (d) Decrease by about 5 %

11. A 3-phase induction motor is required to drive a factory ventilation fan in Singapore. The mechanical facility engineer has determined that the fan requires a torque of 300 Nm to run at a speed of approximately 1000 rev/min. Which of the following motors will you select for the application?

- (a) 3-phase, 50 Hz, 400 V, 50 kW, 2-pole
- (b) 3-phase, 50 Hz, 400 V, 50 kW, 4-pole
- (c) 3-phase, 50 Hz, 400 V, 25 kW, 6-pole
- (d) 3-phase, 50 Hz, 400 V, 50 kW, 6-pole

12. A motor is rated at 200 kW, 970 rev/min. What is the rated torque of the motor?

- (a) 150.8 Nm
- (b) 1969 Nm
- (c) 1358 Nm
- (d) 978.5 Nm

13. In DC-DC converter control loop design, the open loop DC Gain of the converter
- should be as stable as possible
 - should be as accurate as possible
 - should be as high as possible
 - should be as constant as possible
14. In Figure Q14, what is the theoretical maximum voltage encountered by Mosfet Q1 in the converter, given that $V_{DC} = 50V$ and the turn ratio of $N_P:N_S:N_R = 3:2:1$?

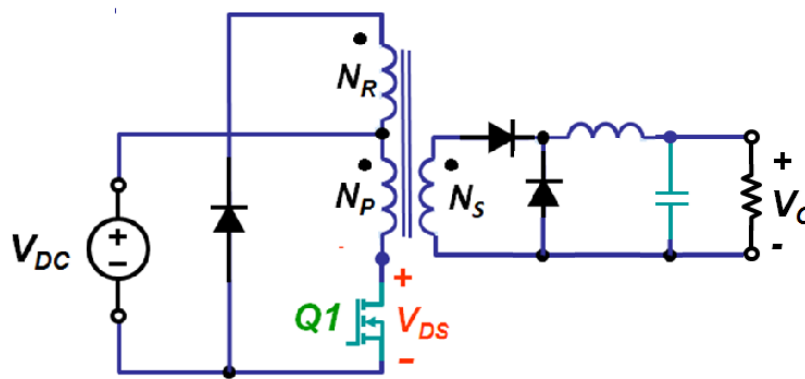

Figure Q14

- 100V
 - 200V
 - 300V
 - 400V
15. If $V_{DC} = 150V$ and Q1 has a maximum voltage rating of 220V, what would be the appropriate breakdown voltage V_Z value of the Zener diode used in the following circuit shown in Figure Q15?

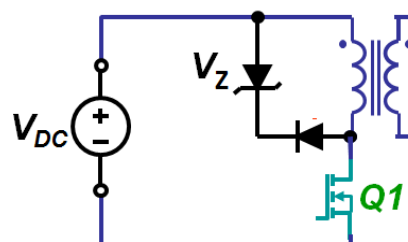

Figure Q15

- 50V
- 100V
- 150V
- 200V

-
16. The governor characteristic of a generator has a three percentage drop in speed from no-load to full load of 200 MW. When the power output of the generator is reduced to 60 % of its rated capacity, determine the new governor setting and associated governor characteristic to maintain the frequency of the machine at 1.0 p.u.
- (a) 1.08 %
 - (b) 1.2 %
 - (c) 1.8 %
 - (d) 5 %
17. A 66 kV, 10 km transmission line delivers power of 100 MW at 0.9 lagging power factor to the load at the receiving end. The parameters of the line are such that the reactance per km is 0.3 ohm, and the resistance and shunt capacitance are negligible. Calculate the sending end voltage to maintain the receiving end voltage at 66 kV.
- (a) 65.03 kV
 - (b) 66.97 kV
 - (c) 68.35 kV
 - (d) 70.58 kV
18. In the solution algorithm of the power flow problems, what would need to be computed first before other quantities are calculated?
- (a) Active and reactive power flows in all the lines
 - (b) Voltage magnitude and phase angle of each bus
 - (c) Active and reactive power losses in each line
 - (d) Line currents
19. In the power flow studies, a generator can regulate its generator bus voltage at a specified value because
- (a) the generator bus voltage is within the high and low voltage limits.
 - (b) the generated active power is within the unit's maximum and minimum P limits.
 - (c) the generated reactive power is within the unit's maximum and minimum Q limits.
 - (d) the supplied generator current is within its rated value.

20. If a power system has 10 load buses and 6 generator buses (inclusive of the slack bus), what is the total number of independent power flow equations that needs to be set up?
- (a) 25
 - (b) 24
 - (c) 23
 - (d) 20

Questions From Past Year Papers for Fundamentals Of Engineering Examination Part 2 (Electrical)

(Actual paper comprises 7 questions. Answer 5 questions)

Q1.

A 100-MVA, 22-kV generator with synchronous reactance of 1.7 pu supplies power to an infinite bus at rated voltage.

- (a) Find the induced emf and the power angle when the generator is supplying 50 MW at 0.85 pf lag.

(5 marks)

- (b) If the steam input is kept constant and the excitation is increased by 15%, determine the induced emf, the power angle, the reactive power, and the power factor of the generator.

(11 marks)

- (c) Is the generator under, normally, or over excited? Why?

(4 marks)

Q2.

A 50-MVA, 12.5 kV generator has a direct-axis sub-transient reactance of 0.25 per unit. The negative- and zero-sequence reactances are, respectively, 0.35 and 0.10 per unit. The neutral of the generator is solidly grounded. When a single line-to-ground fault occurs at the generator terminals with the generator operating unloaded at rated voltage, determine

- (a) the sub-transient current (in amperes) in the generator, and

(8 marks)

- (b) the line-to-line voltages (in kV) for sub-transient conditions.

(12 marks)

Q3.

- (a) A main switch board is supplied from a 22/0.43 kV, 2.0 MVA transformer with an impedance of 6%. The impedance of LV cables to the main switchboard is $(0.0006 + j0.0012) \Omega$. The fault level at the 22 kV intake point is 800 MVA. Calculate the fault current at the main switchboard. State major assumptions you made, if applicable.

(8 marks)

- (b) Electric power distribution systems can be configured in various ways to efficiently deliver electricity to consumers. The choice of configuration depends on factors such as load requirements, geographical location, cost, reliability, maintainability, and future expansion plans. Three common configurations for power distribution systems are:

Radial configuration
 Ring configuration
 Mesh configuration

Briefly discuss three (3) main features, three (3) advantages, and three (3) disadvantages for each of these configurations.

(12 marks)

Q.4

A 400 V three phase Main Switchboard (MSB) as shown in Figure Q4 supplies to a three phase 150 kW electric motor with power factor of 0.85 lagging and efficiency of 90% which is located 80 metres away.

The electric circuit from the MSB to the motor is laid horizontally, touching on a cable tray using single-core, copper conductor, XLPE insulation and PVC sheath cables. The section of the electric circuit from the MSB in the corridor is 25 metres long. It shares with another two circuits and the ambient temperature is 35 °C.

The section of the electric circuit in the furnace room to the motor is 55 metres long and is on its own. The ambient temperature in the furnace room is 50 °C. Overload protection of the cables is by a Triple Pole (TP) MCCB in the MSB. Earth fault protection is by an Earth Leakage Relay with current setting of 2 A and time setting of

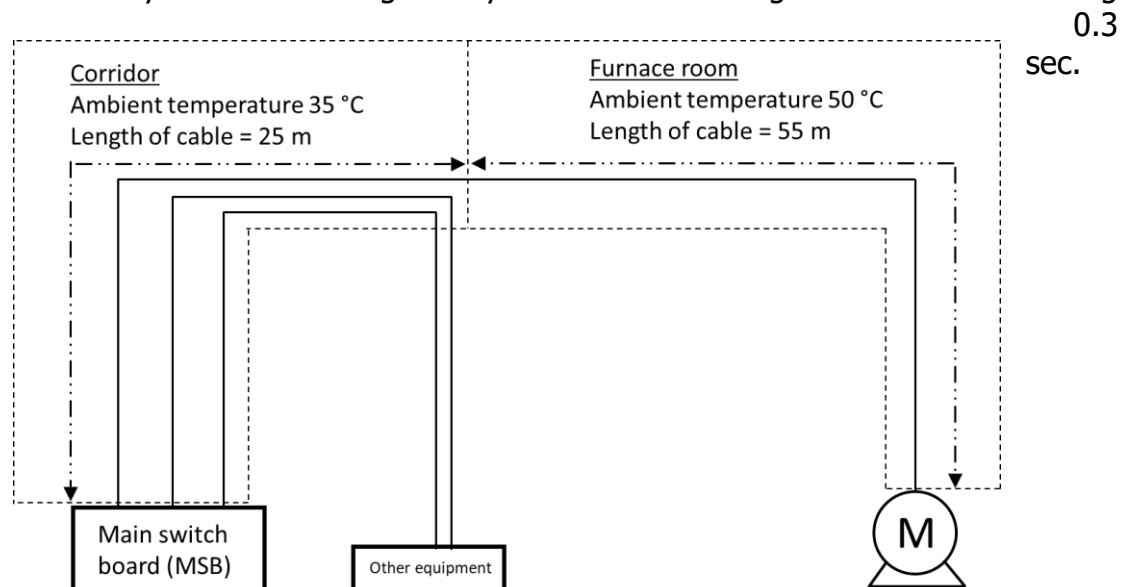

Figure Q4 Power Supply to an electric motor

- (a) Select the appropriate cable size for the cable to the motor. The cable is required to be protected against overload. (6 marks)

- (b) Calculate the voltage drop in the steady load conditions when the motor is operating at full load. (3 marks)
- (c) During motor starting, the power factor drops to 0.3 and the starting current is 3 times the full-load current, calculate the voltage drop during motor starting. (3 marks)
- (d) The earth fault loop impedance measured at the motor is 0.6Ω , what is the prospective earth fault current? (2 marks)
- (e) A single core, copper, PVC insulated cable is used as the circuit protective conductor of the motor, use the Table 5.5 below to determine the cable size of the circuit protective conductor. (2 marks)
- (f) Check whether the circuit protective conductor size is adequate to withstand the thermal effect of the earth fault current. (4 marks)

Available TP MCCB current ratings are 100 A, 200 A, 300 A, 400 A, 600 A, 800 A, 1,000 A

Conductor cross sectional area (mm ²)	Current carrying capacity (amperes) Reference Method 11 (on a perforated cable tray horizontal or vertical) 3 or 4 cables, 3-phase a.c. flat and touching or trefoil (A)	Voltage drop (per ampere per metre) Reference Methods 1&11 (flat and touching) (mV/A/m)		
		r	x	z
35	176	1.15	0.18	1.15
50	215	0.86	0.18	0.87
70	279	0.59	0.175	0.62
95	341	0.43	0.170	0.46
120	398	0.34	0.165	0.38
150	461	0.28	0.165	0.32
185	530	0.22	0.165	0.28
240	630	0.170	0.165	0.24
300	730	0.135	0.160	0.21

Table 4.1: Current carrying capacity and voltage drop of single core copper cables having thermosetting insulation, non-armoured, with or without sheath

Type of insulation	Operating Temp (°C)	Ambient temp (°C)								
		25	30	35	40	45	50	55	60	65
Rubber	60	1.04	1.0	0.91	0.82	0.71	0.58	0.41	-	-
General purpose PVC	70	1.03	1.0	0.94	0.87	0.79	0.71	0.61	0.50	0.35
Paper	80	1.02	1.0	0.95	0.89	0.84	0.77	0.71	0.63	0.55
rubber	85	1.02	1.0	0.95	0.90	0.85	0.80	0.74	0.67	0.60
Heat resisting PVC	90	1.03	1.0	0.97	0.94	0.91	0.87	0.84	0.80	0.76
Thermosetting (e.g. XLPE)	90	1.02	1.0	0.96	0.91	0.97	0.82	0.76	0.71	0.65

Table 4.2: Correction factors for ambient temperature where protection is against short circuit

Reference Method of installation	Correction factor (C_g)					
	Number of circuits or multicore cables					
	2	3	4	5	6	
Enclosed or bunched and clipped direct to a non-metallic surface (Method 1)	0.80	0.70	0.65	0.60	0.57	
Single layer clipped to a non-metallic surface (Method 1)	Touching	0.85	0.79	0.75	0.73	0.72
	Spaced	0.94	0.90	0.90	0.90	0.90
Single layer multicore on a perforated metal cable tray, vertical or horizontal (Method 11)	Touching	0.86	0.81	0.77	0.75	0.74
	Spaced	0.91	0.89	0.88	0.87	0.87
Single layer single core on a perforated metal cable tray, touching (Method 11)	Horizontal	0.90	0.85			
	Vertical	0.85				
Single layer multicore touching on ladder supports (Method 13)	0.86	0.82	0.80	0.79	0.78	

Table 4.3: Correction Factors for groups of more than one circuit of single-core cables, or more than one multicore cable

Material of conductor	Insulation material		
	70 °C thermoplastic	90 °C thermoplastic	90 °C Thermosetting (e.g. XLPE)
Copper	115/103*	108/86*	143
Aluminium	76/68*	66/57*	94
Assumed initial temperature	70 °C	90 °C	90 °C
Final temperature	160 °C / 140 °C	160 °C / 140 °C	250 °C

* Above 300 mm²

Table 4.4 Values of k for protective conductor incorporated in a cable or bunched with cables, where the assumed initial temperature is 70 °C or greater.

Cross-sectional area of the conductor S	Minimum cross-sectional area of the corresponding protective conductor	
	If the protective conductor is of the same material as the line conductor	If the protective conductor is not of the same material as the line conductor
(mm ²)	(mm ²)	(mm ²)
$S \leq 16$	S	$\frac{k_1}{k_2} \times S$
$16 < S \leq 35$	16	$\frac{k_1}{k_2} \times 16$
$S > 25$	$\frac{S}{2}$	$\frac{k_1}{k_2} \times \frac{S}{2}$

K₁ is the value of k for the line conductor

K₂ is the value of k for the protective conductor

Table 4.5 Minimum cross-sectional area of protective conductor in relation to the cross-sectional area of associated line conductor

Q5.

- (a) A 22kV feeder is protected by an IDMT overcurrent relay with IEC standard inverse characteristic. The plug setting (PS) is 5A and time multiplier setting (TMS) is 0.23. Calculate the relay operating time when a current of 10 A and 50 A is injected.

Inverse definite minimum time (IDMT)

$$t = \frac{K \times [\text{TMS}]}{(I/I_s)^\alpha - 1}$$

Where

- t = operation time
- K = constant
- I = fault current
- I_s = current threshold setting
- α = constant
- TMS = time multiplier (0.025 to 1.2 in steps of 0.025)

Curve description	Constants		Minimum operation
Short time inverse	K = 0.05	α = 0.04	1.05 I _s
Standard inverse	K = 0.14	α = 0.02	1.05 I _s

Table 5: Formula and constants of IDMTL characteristic curve to IEC Standard

(5 marks)

- (b) The specifications of a 500/5 current transformer (CT) is 5P20, 5 VA and CT resistance is 0.10 Ω. The CT connected burden is 1.25 VA. Calculate the actual accuracy limiting factor (ALF) and convert it to primary of the CT?

(5 marks)

- (c) A 22 kV/400V 1MVA Dy11 transformer is protected by an IDMTL overcurrent (OC) relay with IEC standard inverse characteristic on the 22 kV side. The current transformer ratio is 75/1. The OC relay plug setting (PS) is 0.75 A and time multiplier setting (TMS) is 0.35.

The transformer LV phase L1 cable developed an earth fault current of 10,000 A. Calculate the relay operating time. Which phase(s) showed trip indication?

(10 marks)

III Fundamentals Of Engineering Examination (Mechanical)

The examination will focus on testing the fundamentals of mechanical engineering. The 6-hour examination will comprise two parts:

Format

- **FEE Part 1 (Mechanical) (3 hours & 10 mins) – 40 MCQ questions**
 - ME 101 Control and Instrumentations
 - ME 102 Dynamics and Vibrations
 - ME 103 Fluid Mechanics
 - ME 104 Mechanics and Materials
 - ME 105 Manufacturing Technology
 - ME 106 Thermodynamics and Heat Transfer

- **FEE Part 2 (Mechanical) (3 hours & 10 mins) – 5 out of 7 questions**
 - ME 201 Control and Instrumentations
 - ME 202 Dynamics and Vibrations
 - ME 203 Fluid Mechanics
 - ME 204 Mechanics and Materials
 - ME 205 Manufacturing Technology
 - ME 206 Thermodynamics and Heat Transfer

Syllabus

- **ME 101/201 Control And Instrumentations**
 - **Modelling of Linear Systems**
Introduction to control systems. Mathematical modelling of electro-mechanical systems. Transfer functions representation of physical components. Block diagram manipulation.
 - **Dynamic Response Analysis**
Transient response analysis and performance indices. Poles and zeros concept, dominant pole concept of high order systems. Characteristic equation. Steady state errors and system types.
 - **Principles of Feedback Control**
Open loop versus closed loop control. Analysis of system type. Error elimination and disturbance rejection. Types of feedback systems. PID controller. Stability and Routh-Hurwitz method.
 - **Root Locus Techniques**
Qualitative analysis of the Root Locus. Guidelines for sketching a Root Locus. General concepts of dynamics compensator design. Design by Root Locus: PI, PD, PID, Lead and Lag compensators. Feedback compensation and realisation.

-
- **Frequency Domain Analysis**
Concept of frequency response. Bode plots. Nyquist plot and Nyquist stability criterion. Stability margins. Closed loop frequency domain characteristics. Design of compensator via Bode plots - Lead, Lag & Lag-lead controller. Design examples.
 - **Measurement System**
Models and classification for measurement systems and their time and frequency domain behaviours. Performance specifications.
 - **Analog Devices and Measurement**
Introduction to basic measurement devices for analog signals and measurement principles. Conditioning of analog signals for transmission and processing.
 - **Digital Devices and Measurement**
Fundamental differences between analog and digital systems. Sampling theorem and fundamentals of data acquisition.
 - **Sensors**
Measurement for common engineering applications: position, speed, stress, strain, temperature, vibration and acceleration, pressure and flow. Semiconductor sensors and micromechanical devices.
 - **ME 102/202 Dynamics And Vibrations**
 - **Dynamics**
 - Kinematics of Particle**
Uniform rectilinear motion; Uniform accelerated rectilinear motion; Rectangular components of velocity and acceleration; Motion relative to a frame in translation; Tangential and normal components; Radial and transverse components. Newton's second law; Equations of motion; Angular momentum of a particle; Principle of conservation of energy; Principle of conservation of momentum.
 - Kinematics of Rigid Bodies**
General plane motion; Coriolis acceleration. Equations of plane motion for a rigid body; Angular momentum of a rigid body in plane motion; Principle of work and energy for a rigid body; Principle of impulse and momentum for the plane motion of a rigid body; Conservation of angular momentum.
 - **Mechanical Vibrations**
 - Vibration Without Damping**
Simple harmonic motion; Energy method; forced vibration.
 - Damped Vibration**
-

Damped free vibration; Damped forced vibration.

- **ME 103/203 Fluid Mechanics**

- **Basic concepts**

Understanding fluids as compared to solids and gases. Properties of fluids: Density, pressure and viscosity. Pressure measurements. Buoyant forces and Archimedes' Principle. Stability of submerged and floating bodies. Stability of a ship.

- **Fluid Motion**

Real and ideal fluids. Momentum and forces in fluid flow: Continuity equation, momentum equation, energy equation, Bernoulli's equation.

- **Pipe Flow**

Laminar and turbulent flows in pipes. Moody diagram, losses and fittings, energy equation for real laminar flow in pipes. Equation of motion for turbulent flow. Mixing length hypothesis. Fully turbulent flow in pipes. Head and flow calculations in pump-piping systems.

- **Fluid Machinery**

Fundamental theory and performance. Pumps and fans, turbines: Concepts and performance characteristics. Cavitation and surge phenomena.

- **Flow Resistance and Propulsion**

Boundary layer, surface roughness, form drag. Water jet theory: Basic principle, fundamental thrust equation. Ship propulsion: Introduction to propulsion system, powering of ship, propeller theory, propeller-hull interaction.

- **ME 104/204 Mechanics And Materials**

- **Material properties and behaviour**

Yield and ultimate tensile stress, proof stress, elastic modulus. Yield and Strength failure criteria- Tresca and Von-Mises.

Temperature effects- temperature expansion coefficient, creep and stress relaxation. Post-yield effects- elastic-plastic, bilinear hardening and strain hardening. Fatigue effects- S/N curves.

- **Stress and Strain**

Basic stress and strain for elastic bodies- direct stress and strain, shear stress and strain, Mohr's circle. Stress and Strain transformations - two and three-dimensional, 4 elastic constants E , ν , k and G .

- **Bending of beams**

Second moments of area of structural sections, Free body, shear force and bending moment diagrams. Elastic and inelastic bending of

beams. Combined tension and bending of beams, Deflection and slopes of beams. Shear stress in beams, Statically indeterminate beams.

- **Bending of plates and cylindrical shells**

Symmetric membrane bending theory of circular plates and shells under fixed and freely supported boundaries. Discontinuity stresses of cylinder to flat, cone or hemispherical shells junctions.

- **Torsion of prismatic bars and closed sections**

Torsion of circular solid section and open thin-walled sections, shear stresses and deformation, shear flow in thin walled open and closed sections.

- **Buckling of columns**

Euler buckling theory, perfect and imperfect columns, effect of end fixings on critical buckling loads.

- **Thermal loading**

Thermal stresses in beams and cylinders due to a through thickness temperature gradient, thermal stresses in compound bars of different materials under uniform temperature.

- **Internal pressure loading**

Membrane theory, thin and thick-walled cylinders under pressure.

- **ME 105/205 Manufacturing Technology**

- **Introduction**

Cutting tool materials. Single and multi-point tools. Types of wear. Manufacturing processes: cold and hot working, rolling, extrusion, forging, sheet and metal blanking and forming, cold forming, welding, brazing, soldering, casting, powder metallurgy, plastics technology. Non-conventional machining: electro-discharge machining.

- **Metal Removal**

Introduction to machine tools and machining operations – Generating motions of machine tools, machines using single point tools, machines using multipoint tools, machines using abrasive wheels. Mechanics of metal cutting – Chip formation, forces acting on the cutting tool and their measurement, the apparent mean shear strength of the work material, chip thickness, friction in metal cutting. Cutting tool materials – Major tool material types. Tool life and tool wear – Forms of wear in metal cutting. Economics of metal cutting operations – Choice of feed, speed and depth of cut, tool life for minimum cost and minimum production time, estimation of factors needed to determine optimum conditions.

- **Metrology**

Basic measuring instruments and their applications (Linear and angular measurement, roundness, flatness and surface finish measurement).

- **Manufacturing Processes**

Introduction to cold and hot working. Rolling - 2, 3 and 4-high rolls, cluster and planetary rolls, manufacture of blooms, billets and slabs. Extrusion - Direct and indirect extrusion, hollow extrusion, hydrostatic extrusion. Forging - Hammer, press, roll forging, open and closed die forging. Sheet metal bending and deep-drawing, punch load, drawability, Crane's constants. Shearing of sheet metal - types of shearing operation, punch and die clearance, punch force. Cold forming processes - Marforming, Guerin process, hydroforming. Welding, brazing, soldering - Arc and gas welding, pressure welding, MIG, TIG, submerged-arc, friction, resistance, laser and electron-beam welding. Casting - Sand casting, patterns, defects, die-casting, centrifugal casting, investment casting, continuous casting. Powder metallurgy - Production of powders, fabrication processes, sintering, comparison with other processes. Electro-discharge machining. Plastics technology – Properties of plastics, thermoplastics and thermosets, manufacturing of plastics.

- **ME 106/206 Thermodynamics And Heat Transfer**

- **Thermodynamics**

- Fundamental concepts**

- Simple concept of thermodynamic system. Types of energy interaction between system and surroundings. Properties of simple pure substances –understand the general form of property diagrams. Empirical temperature scales and thermometry. Ideal and perfect gases. Use of steam tables for substance such as water.

- First Law of Thermodynamics**

- The concept of fully-resisted or quasi-static processes; work and heat interactions in adiabatic boundaries with the introduction of internal energy, kinetic, potential and enthalpy. Statement of the First law of Thermodynamics: applications relating to non-flow and simple unsteady flow (e.g., the filling of a rigid vessel) processes. First law applied to simple thermodynamic plants, e.g. power plant, compressors and expanders (without detailed knowledge of plant construction). Steady flow energy equation and its application to demonstrate the significant of enthalpy changes.

- Second Law of Thermodynamics**

- Alternative statements of the Second Law. Reversible and irreversible processes. Internal and external irreversibility. Heat

engines operating in temperature reservoirs and the efficiency of reversible engines. Entropy as a property and its relationship to heat transfer. The Clausius inequality. Isentropic and non-isentropic processes.

- **Heat Transfer**

- **Conduction**

- Heat transfer by conduction. Steady-state conduction through slab, compound walls, cylinders and spheres. Unsteady state conduction in homogeneous solids.

- **Convection**

- Heat Transfer by convection, in fluids and films. Overall heat transfer coefficients. Natural and forced convection on plane surfaces, fins, pipes and around round bundles. Heat transfer in extended surfaces- combining conduction and convection.

- **Radiation**

- Heat transfer by radiation. Laws of radiant heat transfer, black and gray bodies, geometric factors, absorptivity.

Recommended Reading List for Mechanical Engineering

- **ME 101/201 Control And Instrumentations**
Katsuhito Ogata, "Modern Control Engineering", 5th edition, published by Prentice Hall
- **ME 102/202 Dynamics And Vibrations**
F.B. Beer, E.R. Johnston, and W.E. Clausen, "Vector Mechanics for Engineers – Dynamics" S I version
- **ME 103/203 Fluid Mechanics**
B.R. Munson, D.F. Young, and T.H. Okiishi, "Fundamentals of Fluid Mechanics", published by John Wiley and Son
F.M. White, "Fluid Mechanics", 7th edition, published by McGraw-Hill
- **ME 104/204 Mechanics And Materials**
C. Ugural, "Mechanics of Materials", published by McGraw-Hill
R.C. Hibbeler, "Mechanics of Materials", 2nd edition SI version, published by Prentice Hall
- **ME 105/205 Manufacturing Technology**
S. Kalpakjian, and Steven R. Schmid, "Engineering & Technology"
W.A. Knight, and G. Boothroyd, "Fundamentals of Metal Machining and Machine Tools"
- **ME 106/206 Thermodynamics And Heat Transfer**
Y.A. Cengel, and M.A. Boles, "Thermodynamics: An Engineering Approach", 8th edition SI version, published by Mc-Graw Hill
Incropera, and DeWitt, "Fundamental of Heat and Mass Transfer"
J.P. Holman, "Heat Transfer", published by McGraw-Hill

Questions From Past Year Papers for Fundamentals Of Engineering Examination Part 1 (Mechanical)

(Actual paper comprises 40 Multiple Choice Questions (MCQ) of 2.5 marks each. Answer all questions.)

1. A rectangular wooden fin of cross section 200 mm by 600 mm protrudes from the bottom of a motor boat moving at 5 m/s. What is the maximum pressure on the fin? Density of water is 1000 kg/m^3 .
 - (a) 2.50 kPa
 - (b) 5.00 kPa
 - (c) 12,50 kPa
 - (d) 25.00 kPa

2. A pump is required to deliver $0.5 \text{ m}^3/\text{s}$ of cooling water through a pipe of 75-mm diameter to a heat engine which is 200 m away from and 2 m higher than the pump. Density of water is 1000 kg/m^3 . What is the power of the pump?
 - (a) 1000 W
 - (b) 4905 W
 - (c) 9810 W
 - (d) 19620 W

3. The main reason for incorporating an air pre-heater in the furnace of a steam power plant is
 - (a) to have a complete combustion in the furnace
 - (b) to decrease the humidity of air in the exhaust flue gases
 - (c) to minimize the energy input to the combustion process
 - (d) to maximize the waste heat rejection in the exhaust

4. In a stoichiometric combustion, the air to fuel ratio is
 - (a) below the user defined value
 - (b) higher than its natural ability to burn
 - (c) the chemically correct value
 - (d) a burning scenario when the flame is seen to be yellow in colour

5. The coefficient of performance (COP) of a vapour compression chiller is characterized by its cooling capacity. At low cooling rates, the chiller COP is reduced by the effects of heat leaks to the environment. On the other hand, at high cooling rates, the chiller suffers from
- the high vibration of the major moving parts
 - the inefficient operation of the expansion device
 - the high mass leaks in the vapour compression machine
 - the finite-rate of heat transfer and fluid friction losses of the working fluid

6. Which of the following statement is correct?

- Tool life increases with the increase of cutting speed
- Tool life decreases with the increase of cutting speed
- Cutting speed has no influence on tool life
- None of the above

7. Consider the unity-feedback control system with the following open-loop transfer function:

$$G(s) = \frac{10}{s(s-1)(2s+3)}$$

It is:

- stable
- unstable
- marginally stable
- conditionally stable

8. Referring to the system shown below, determine the values of K and k such that the system has a damping ratio ζ of 0.7 and an undamped natural frequency ω of 4 rad/sec.

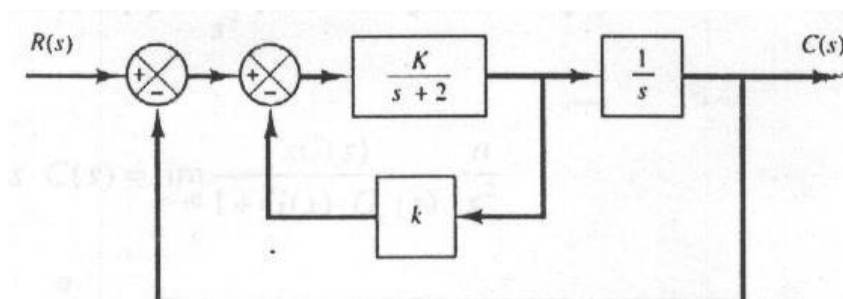

- 16, 0.225
- 4, 0.225
- 16, 0.05
- None of the above

-
9. Design a solid shaft to transmit 200 KW at 75 rpm without exceeding a shearing stress of 43 MPa.
- (a) 54.8mm
 - (b) 72mm
 - (c) 0.144mm
 - (d) 144mm
10. A beam having a rectangular section of 100mm width by 150mm depth is subjected to a positive bending moment of 16 KNm acting about the horizontal axis. Find the bending stress acting at the section 25mm above the neutral axis.
- (a) 114.22 MPa
 - (b) 72.11 MPa
 - (c) 0.114 MPa
 - (d) 28.44 MPa

Questions From Past Year Papers for Fundamentals Of Engineering Examination Part 2 (Mechanical)

(Actual paper comprises 7 questions. Answer 5 questions.)

Q1.

A combined cycle power plant comprises a natural gas fired, ideal gas-turbine topping cycle and a bottoming steam-generator for the steam turbine. The air inlet pressure and temperature to the gas turbine, which has a pressure compression ratio of 8, are 1 bar and 300K, respectively. The temperature of burned gases from the combustor to the turbines is 1400K and the flue gas temperature leaving the steam generator (heat exchanger) is 520K. The bottoming cycle of the power plant is an ideal reheat Rankine cycle where the steam pressure and temperature supplied to the high pressure steam turbines are 150 bar and 450 C. Additional natural gas is fired for the reheating of steam and the conditions of reheated steam supplied to low-pressure turbine stage are 30 bar and 500° C, respectively.

(a) For the stated steady state conditions, sketch the combined cycle on a T-s diagram.

(4 marks)

(b) Using the thermodynamic properties of air and steam from the Tables, determine;

- (i) the mass flow rate of air in the gas turbine cycle if the steam generation rate is 30 kg/s,
- (ii) the rate of total heat input, and
- (iii) the thermal efficiency of the combined cycle.

State all assumption made in the solution.

(16 marks)

Q2.

A solid aluminium shaft 1.0m long and 50mm diameter is to be replaced by a tubular steel shaft of the same length and same outer diameter so that either shaft could carry the same torque and have the same angle of twist over the total length (that is having the same torsional stiffness).

Calculate the inner diameter of the tubular steel shaft.

The following properties of steel and aluminium can be used in your calculation. Steel, $G_s = 84$ GPa, Aluminium $G_a = 28$ GPa.).

(20 marks)

Q3.

A mercury-in-bulb thermometer is immersed into a bath of temperature T_i , and the mercury level in the stem of radius r_s rises by a finite height X_o . If the bulb has a radius r_b , and the overall heat transfer coefficient between the bulb and the fluid of the bath is U , show that the energy balance equation for the temperature of mercury in the bulb (T_b) is given by

$$\rho CV_b \left(\frac{dT_b}{dt} \right) = UA_b(T_i - T_b)$$

where ρ is the density of mercury in the bulb, C is the specific heat, A_b is the surface area of the bulb. Assuming that the expanded mercury of the bulb ($\beta V_b T$) is equal to the change of the mercury volume in the stem ($X_o A_s$), demonstrate that the output variable (X_o) to the input variable (T_i) can be expressed as

$$\left[\frac{\rho CV_b}{UA_b} \right] \left(\frac{dX_o}{dt} \right) + X_o = \left[\frac{\beta V_b}{A_s} \right] T_i \quad \square$$

where A_s is the cross section area of the hollow stem of thermometer. Using the operator D or equivalent, demonstrate that the thermometer can be expressed as a 1st order transfer function in terms of X_o to T_i as;

$$(\tau D + 1)X_o = K T_i$$

Hence, show that $K = \frac{\beta V_b}{A_s}$, a constant and $\tau = \frac{\rho CV_b}{UA_b}$, is the time constant of the thermometer.

Write down the general solution of the output variable, X_o . Sketch the expected behavior of the thermometer over a finite non-dimensional time intervals, t/τ , say from 0 to 5.

(12 marks)

A mercury-in-bulb master thermometer is designed with a bulb radius of 1.6 mm whilst the ratio of the hollow stem to bulb radii is 0.07. If the overall heat transfer coefficient between the thermometer and the bath fluid is 800 W/m².K, show that:

- (i) the time constant (τ) of the thermometer is about 4 s,
- (ii) the ratio of thermometer constant (K) to the volumetric expansion coefficient of mercury (β) is about 0.1.

The following properties of mercury can be used in your calculation: Density (ρ) and specific heat (C) of mercury are 13500 kg/m³ and 140 J/kg.K, respectively.

(8 marks)

IV Fundamentals Of Engineering Examination (Chemical)

The examination will focus on testing the fundamentals of chemical engineering. The 6-hour examination will comprise two parts:

Format

- FEE Part 1 (Chemical) (3 hours & 10 mins) – 40 MCQ questions
- FEE Part 2 (Chemical) (3 hours & 10 mins) – 5 out of 7 questions

Syllabus

- **ChE 101: Chemical Engineering Principles**
 - **Mass balances**
Unit conversion, process flow chart, phase behavior, composition, purge, bypass, reactive systems, multiple reactions, recycle, combustion.
 - **Energy balances**
Heat capacity, Latent heat, heat of reaction, heat of solution.
- **ChE 102: Thermodynamics**
 - **Thermodynamic properties and phase diagrams**
Enthalpy, entropy, free energy, steam tables.
 - **Thermodynamic laws and applications**
First law, Second law, isothermal processes, adiabatic processes, cyclic processes (e.g. power cycles, refrigeration).
 - **Chemical thermodynamics**
Phase equilibrium, chemical equilibrium, heats of reaction and mixing.
- **ChE 103: Transport Processes**
 - **Momentum transfer**
Classification of fluids and their properties. Continuity equation. Momentum balance equation. Bernoulli equation. Flow of compressible fluids. Friction losses in flow. Equivalent diameter for non-circular conduct. Pumps and Compressors: characteristics curves, net positive suction head (NPSH), cavitation, and selection of pumps and compressors.
 - **Heat transfer**
Basic definitions. Steady state heat conduction. Thermal resistor models for composite walls. 1-D analysis of unsteady state heat

conduction. Natural and forced convection. Heat exchangers. Black body radiation and calculation of energy loss from surface.

- **Mass Transfer**

Fick's laws. Estimation of gas and liquid phase diffusivities. Steady-state and unsteady state diffusion. Pore diffusion. Convective mass transfer – calculations of fluxes and mass transfer coefficients. Mass, heat and momentum transfer analogies.

- **ChE 104: Chemical Reactors**

Kinetics versus thermodynamics of chemical reactions. Reaction rates. Rate laws. Reaction stoichiometry versus reaction mechanism. Stoichiometric table analysis. Ideal reactor design equations. Analysis of reaction rate data. Reactor selection and sequencing. Yield versus productivity in multiple reactions. Non-isothermal operations. Residence time distributions as reactor diagnostics. Coupling of transport processes to chemical reactions. Reactors for heterogeneous catalysis.

- **ChE 105: Separation**

Phase equilibrium, partition coefficient, driving force and mass transfer rate in the context of separation processes. Mass and energy balances around flash distillation, multi-stage distillation, absorption and stripping, and liquid-liquid extraction and membrane processes. Equilibrium and rate based design concepts of these separation processes for binary and multi-component systems. Effects of various operating variables on the separation process output, troubleshooting and process improvement.

- **ChE 106: Process Control**

Importance of process control in chemical process industry. Architecture and hardware of a control system. Measurement noise and observability of a process variable. Dynamic behavior of a chemical process (first order, second order, dead time, recycle, etc.), and various types of open loop and closed loop responses. Types of control systems (feedback, feed forward, cascade, ratio, etc.) and their selection for a given application. Design/tuning of industrially relevant feedback controllers and their stability. Unit level (reactor, distillation column, etc.) versus plant wide control.

- **ChE 107: Process Design & Safety**

- Need for process simulation, design, and optimization. Plant life cycle and plant design stages. Fundamentals of process simulation, process simulators and their architecture. Hierarchical approach to preliminary process synthesis. Heat integration. Process diagrams. Process optimization. Equipment selection, specification, sizing and costing. Time value of money. Plant cost estimation and profitability analyses (payback period, NPV, RORI, ...).

- Importance of occupational health and loss prevention. Hazards, risks, and incident statistics. Toxic hazards, threshold limit values; Probit analysis. Industrial hygiene evaluation and control. Toxic release estimation, consequence analyses, and exposure limits. Fires and explosions, flammability and limits, and fire/explosion prevention. Relief systems and sizing. Hazard identification and risk assessment.

Recommended Reading List for Chemical Engineering

ChE 101: Chemical Engineering Principles

- 1) R. M. Felder, R. W. Rousseau and L. G. Bullard, "Elementary Principles of Chemical Processes" 4th edition (2015), John Wiley and Sons, Inc.

ChE 102: Thermodynamics

- 1) J. M. Smith, H. Van Ness, M. Abbott and M. Swihart, "Introduction to Chemical Engineering Thermodynamics" 8th edition (2018), McGraw-Hill.

ChE 103: Transport Processes

- 1) WELTY J.R., RORRER G. & FOSTER D.G. (2015) *Fundamentals of Momentum, Heat, and Mass Transfer, International Student Version*, 6th Edition. Publisher John Wiley & Son, New York.

ChE 104: Chemical Reactors

- 1) Octave Levenspiel, *Chemical Reaction Engineering*, 3rd Edition (1999), John Wiley and Sons.
- 2) H Scott Fogler, *Elements of Chemical Reaction Engineering*, 4th Edition (2006), Prentice Hall International Series.

ChE 105: Separation

- 1) Philip C. Wankat, *Separation Process Engineering*, 5th Edition (2023), Pearson Education International.
- 2) J D Seader and Ernest J Henley, *Separation Process Principles*, 2nd Edition (2006), John Wiley and Sons, Inc.

ChE 106: Process Control

- 1) Dale E Seborg, Thomas F. Edgar, Duncan A. Mellichamp and Francis J Doyle III, *Process Dynamics and Control*, 4th Edition (2016), John Wiley and Sons, Inc.
- 2) George Stephanopoulos, *Chemical Process Control: An Introduction to Theory and Practice*, Paperback Edition (2015), Pearson Education International.

ChE 107: Process Design & Safety

- 1) Ray Sinnott and Gavin Towler, *Chemical Engineering Design*, 5th Edition (2009), Elsevier (Butterworth & Heinemann).
- 2) R Turton, R C Bailie, W B Whiting, J A Shaeiwitz, D Bhattacharya, *Analysis, Synthesis, and Design of Chemical Processes*, 4th Edition (2013), Pearson Educational International.
- 3) D Crowl and J F Louvar, *Chemical Process Safety: Fundamentals with Applications*, 2nd Edition, Prentice Hall, 200

Sample Questions for Fundamentals Of Engineering Examination Part 1 (Chemical)

(Actual paper comprises 40 Multiple Choice Questions (MCQ) of 2.5 marks each. Answer all questions.)

1. A distillation column strips ethanol from a feed of 3 mol% ethanol in water. The feed rate is 16000 mol/h. The distillate contains 87 mol% ethanol, and the bottoms contains 0.05 mol% ethanol. What is the flow rate of the distillate?
- (a) Cannot be calculated
(b) 321 mol/h
(c) 432 mol/h
(d) 543 mol/h

2. One mole of ideal gas at 26°C undergoes isothermal compression from 0.5 bar to 2.5 bar. What is the work done on the gas?
- (a) 350 J
(b) 1950 J
(c) 3000 J
(d) 4000 J

3. The vapour-pressure data for benzene is given in the table below:

Pressure (mmHg)	Temperature (°C)
40	7.6
80	21.6

Use the data given to estimate the latent heat of vapourization of benzene.

- (a) 33.8 kJ/mol
(b) 67.6 kJ/mol
(c) 94.5 kJ/mol
(d) 113 kJ/mol
4. Which of the following governs the diffusion of one species onto another?
- (a) Fourier's Law
(b) Fick's Law
(c) Euler's Law
(d) Reynolds Number

5. Steam reforming of methane (SRM) is a high temperature (700-1000C) catalytic reaction for producing hydrogen by splitting water. The product is a mixture of CO and H₂ generally known as the synthesis gas.



The water-gas shift (WGS) reaction also occurs under the steam reforming conditions.

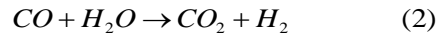

Which of the following statements is correct for maximizing hydrogen production?

- (a) The water-gas shift reaction is always desirable.
 (b) The water-gas shift reaction is always undesirable.
 (c) The water-gas shift reaction is desirable only if methane is in excess.
 (d) The water-gas shift reaction is desirable only if steam is in excess.
6. Which one of the following separation methods is the preferred current option for capture and concentrate of CO₂ from a power plant flue gas?
 (a) Multi-stage distillation
 (b) Extraction
 (c) Absorption
 (d) Flash distillation
 (e) Ion exchange
7. What type of control system has been implemented in the heating process in Figure Q6?

- (a) Feedback control
 (b) Ratio control
 (c) Cascade control
 (d) Feed forward control
 (e) Model predictive control

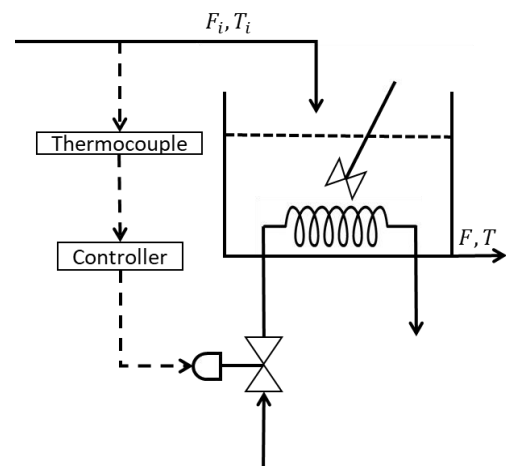

Figure Q6: Controlling temperature in a tank.

8. What is the role of a fluid property package in a process simulator such as Aspen Hysys or Aspen Plus?
- (a) Estimate reaction related properties such as rate/equilibrium constants
 - (b) Perform mass and energy balances
 - (c) Estimate thermophysical properties of streams
 - (d) All of the above

Sample Questions for Fundamentals Of Engineering Examination Part 2 (Chemical)

(Actual paper comprises 7 questions. Answer 5 questions.)

Q1.

Methanol is produced commercially from synthesis gas according to the reactions below:

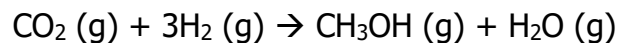
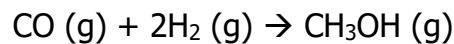

Fresh feed containing 660 mol/s CO, 260 mol/s CO₂, 2200 mol/s H₂, and 50 mol/s inert is mixed with a recycle stream before feeding to a reactor. The feed to the reactor contains 11 mol% inert. A distillation train separates the components of the reactor effluent: the product methanol is withdrawn, water is removed, the remaining gas stream consisting of CO, CO₂, H₂ and 15 mol% inert is recycled to mix with the fresh feed before charging to the reactor. In order to prevent the buildup of inert in the system, a purge stream is withdrawn from the recycle. The production rate of CH₃OH is 870 mol/s.

(a) Draw and label a flowchart of the entire process.

(3 marks)

(b) Calculate the overall conversion of CO, the overall conversion of CO₂ and the single pass conversion of H₂ in the reactor.

(17 marks)

Q2.

A steam power plant operates on the reheat Rankine cycle. Steam enters the high-pressure turbine at 20 MPa and 600°C and leaves at 3.0 MPa. Steam is then reheated at constant pressure in the low-pressure turbine and exits with a moisture content of 15%. The pump and turbines are isentropic. Steam leaves the condenser as a saturated liquid at a pressure of 10 kPa. The mass flow rate of steam is 35 kg/s.

Determine the thermal efficiency of the cycle and the total power output from the 2 turbines.

(20 marks)

Q3.

A large wall has two layers. The outer layer has a thickness 5 cm and is made of firebrick (thermal conductivity, $k = 0.1 \text{ W/m}\cdot\text{K}$). The inner layer has a thickness of 1 cm and is made of insulating brick ($k = 1.5 \text{ W/m}\cdot\text{K}$). The surface of the outer layer is exposed to hot air at $100 \text{ }^\circ\text{C}$ with a convective heat transfer coefficient of $10 \text{ W/m}^2\cdot\text{K}$. The inner surface is exposed to cool air at $10 \text{ }^\circ\text{C}$ with a convective heat transfer coefficient of $3 \text{ W/m}^2\cdot\text{K}$. Calculate the rate of heat transfer across the thickness of the wall.

(20 marks)

Q4.

A pharmaceutical company is considering a process change from batch manufacturing to continuous manufacturing using mostly existing resources. You as the lead process engineer is supposed to carry out a feasibility study and advise the management for a go/no-go decision. The following are the salient process details:

The production process is based on a 1st order liquid phase reaction carried out to 95% completion. Presently this is done in a large 100 L stirred tank reactor. The reaction time to achieve 95% conversion in this reactor is 20h. 4h of turnaround is however needed in between the batches. Feed from the supplier is available at the strength of 1 mole/Litre.

(20 marks)

Q5.

CO_2 capture and concentration from post-combustion power plant flue gas is a problem of urgent importance. In Singapore, 85% of the electricity is produced from natural gas, which produces flue gas with relatively low CO_2 concentration (5-6% versus up to 15 % in coal fired power plants). Other components of flue gas are O_2 , N_2 and moisture. We assume that the flue gas contains 5 mole% CO_2 , 10 mole% and 85 mole% N_2 . Other relevant information: (i) a 500 MW natural gas based power plant emits 6500 tonnes/day of CO_2 , (ii) 1 tonne = 1000 kg, (iii) molecular weight of CO_2 is 44, (iv) molecular weight of N_2 is 28 (v) molecular weight of water is 10, and (vi) gas constant, $R_g = 8.314 \text{ J/mol K} = 82.05 \text{ atm cc/mol K}$.

Design a packed bed absorption process for capturing 90% CO_2 from the flue gas of a 500 MW natural gas fired power plant in Singapore. You may assume that the solvent/reagent undergoes very fast reaction with CO_2 such that the reagent concentration may be adjusted to completely eliminate the liquid side mass transfer resistance. As an approximation, you may assume that gas side mass transfer coefficient, $k_g = 0.2 \text{ cm/s}$ and the area to absorber volume ratio (a) of the packing used is $2 \text{ cm}^2/\text{cm}^3$. Length to diameter ratio of the absorber should not be more than 3. Make reasonable assumptions including operating superficial gas velocity (u) and state them clearly. For a gas side controlled absorption process, absorber length is given by $L = \frac{u}{k_g a} \ln \frac{y_{in}}{y_{out}}$ where y is the mole fraction of the absorbable component.

(20 marks)

Q6.

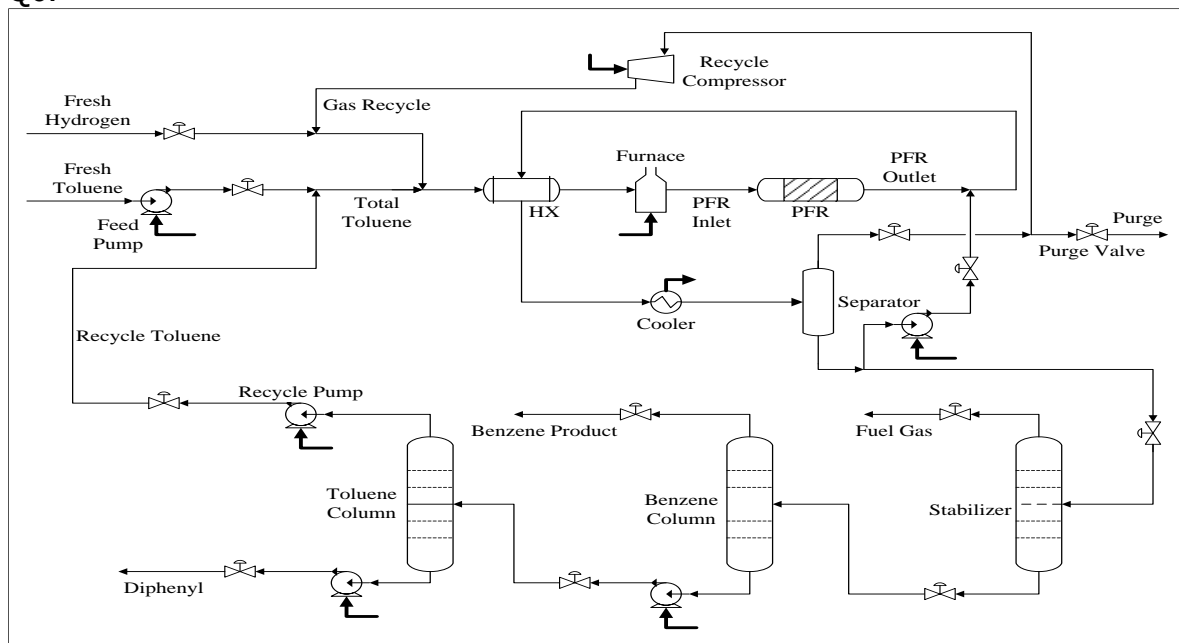

Figure Q6: Process flow diagram for toluene hydrodealkylation process to produce benzene. Separator is a flash distillation unit. Toluene column, benzene column and stabilizer are multistage distillation columns with condenser and reboiler.

In the process flow diagram in Figure Q6, hydrogen and toluene are converted into benzene in the vapour reactor (PFR), with methane and diphenyl as by-products. The effluent from the adiabatic reactor is quenched with liquid from the separator. The separation section comprising three multi-stage distillation columns purifies the benzene product and recovers and recycles unreacted toluene. The partial condenser in the stabilizer unit removes any remaining hydrogen and methane gas from the liquid components. The toluene column bottoms is almost pure stream of diphenyl by-product formed in the reactor.

The benzene producing reaction is exothermic. Feed hydrogen-to-aromatics ratio to the reactor must be at least 5:1. The reactor inlet temperature is 1150°F, and maximum permissible temperature is 1300°F. Reactor effluent gas is quenched to 1150°F

You are in charge of designing a plant wide control system for the process shown in Figure 1. Discuss your control system design philosophy, and identify the controlled and manipulated variables.

(20 marks)

Q7.

You are asked to develop a process to mix two separate feeds (F1 and F2) into one single product stream. F1 is a pure water stream available at 100 kg/s, 150 kPa, and 40 C. F2 is 80:20 wt% ethanol:water stream available at 150 kg/s, 250 kPa, and 95 C. The process should deliver the product stream at 500 kPa and exactly 50 C. Assume the three stream pressures are fixed by the upstream and downstream processes.

- (a) The normal boiling points of water and ethanol are 100 C and 78 C respectively. Describe the main steps of a procedure you can use to determine if F2 is a liquid, vapour, or vapour-liquid stream. What data will you need? What tool will you use?
- (b) Propose and schematically draw two plausible alternate (different) PFDs (Process Flow Diagrams) for the process. The PFDs must show all the units (including any major valves) and utilities (if any) with equipment types, labels, and reasonable symbols. Indicate only those process conditions you can compute or estimate.
- (c) State roughly which factors will you consider and how you would evaluate the two PFDs to select one of them.

(20 marks)