

PRACTICE *of* Professional Engineering Examination 2024

Information for Applicants



Professional Engineers Registration Examination Practice of Professional Engineering Examination 2024 Information for Applicants

| Contents | Page |
|---|-------------|
| 1 Introduction | 2 |
| 2 Description of Examination | 2 |
| 3 Eligibility to Sit for Examination | 2 |
| 4 Fees | 3 |
| 5 Date of Examination..... | 3 |
| 6 Venue | 3 |
| 7 Application | 3 |
| 8 Structure of Examination | 4 |
| 9 Passing Requirements Final Results and Notification | 4 |
| 10 Examinations Appeals..... | 5 |
| 11 Review Courses | 5 |
| 12 Refund of Fees | 5 |
| 13 Request for Accommodation | 5 |

Annex A: FORMAT, SYLLABUS AND SAMPLE QUESTIONS

| | |
|---|----|
| I Practice of Professional Engineering Examination - Part 1 (Common)..... | 6 |
| II Practice of Professional Engineering Examination - Part 2 (Civil)..... | 11 |
| III Practice of Professional Engineering Examination - Part 2 (Electrical)..... | 24 |
| IV Practice of Professional Engineering Examination - Part 2 (Mechanical)..... | 37 |
| V Practice of Professional Engineering Examination – Part 2 (Chemical)..... | 48 |

Professional Engineers Registration Examination Practice of Professional Engineering Examination 2024 Information for Applicants

1 INTRODUCTION

The mission of the Professional Engineers Board is to safeguard life, property, and welfare of the public by setting and maintaining high standards for registering professional engineers and by regulating and advancing the practice of professional engineering.

The Professional Engineers Board registers professional engineers in the branches of civil, electrical, mechanical and chemical engineering. A person applying for registration as a professional engineer to the Professional Engineers Board is required to hold an approved degree or qualification listed in the [Professional Engineers \(Approved Qualifications\) Notification](#) and acquired not less than 4 years of relevant practical experience. He is also required to sit and pass examinations prescribed by the Board. In addition, the applicant is required to attend an interview.

The following sections set out the requirements and details for the Practice of Professional Engineering Examination 2024 while details on other application requirements are available on the PEB website at www.peb.gov.sg.

2 DESCRIPTION OF EXAMINATION

The Practice of Professional Engineering Examination tests the applicant's ability to apply his knowledge and experience in professional engineering practice, and his knowledge of the rules and regulations regulating the practice of professional engineering in civil, electrical, mechanical or chemical engineering.

3 ELIGIBILITY TO SIT FOR EXAMINATION

A person may apply to sit for the Practice of Professional Engineering Examination after he has-

- (a) obtained not less than 2 years 6 months of practical experience in engineering work relevant to the branch of engineering that he seeks to be registered in; and
- (b) sat for and passed the Fundamentals of Engineering Examination.

4 FEES

The fee for an application to sit for the Practice of Professional Engineering Examination is \$450.

5 DATE OF EXAMINATION

The dates for the Practice of Professional of Engineering Examination 2024 are:

- a) Chemical Engineering – 11 September 2024 (Wednesday)
- b) Civil Engineering – 11 September 2024 (Wednesday)
- c) Electrical Engineering – 11 September 2024 (Wednesday)
- d) Mechanical Engineering – 11 September 2024 (Wednesday)

6 VENUE

The venue would be determined by PEB and successful applicants would be informed of the details of the venue.

7 APPLICATION

Application and payment shall be made online at PEB's website by 15 June 2024. Refer to the Application Guide for submission of application. Applicants are advised to send in their applications early to allow time for processing.

8 STRUCTURE OF EXAMINATION

A summary of the structure of the Practice of Professional Engineering Examination 2024 is shown in the table below. The examination is 'open book' and further details are given in [Annex A: Format, Syllabus and Sample Questions](#).

| Subjects | Time Allocated | Format |
|--|-----------------|---|
| <u>PPE Part 1</u> Common paper | 2 hours 10 mins | <ul style="list-style-type: none"> • Answer 10 compulsory Multiple Choice Questions • Answer 3 out of 5 essay questions |
| <u>PPE Part 2</u> Civil/mechanical/ electrical/chemical engineering | 4 hours 10 mins | <ul style="list-style-type: none"> • Answer 1 compulsory question plus 4 out of 7 questions |

(Note: For PPE 2024 Part 2 Civil, only answers based on Eurocodes will be accepted. Answers based on Singapore/British Standards will not be accepted.)

9 PASSING REQUIREMENTS, FINAL RESULTS AND NOTIFICATION

- A candidate is required to take both Parts 1 and 2 when he sits for the examination unless he qualifies for an exemption as described in (b) below. Examination results will be given to candidates on a Pass/Fail basis and no scores or marks will be given to candidates. To obtain a 'Pass' in the examination, a candidate is required to obtain a pass score in both Parts 1 and 2 respectively.
- A candidate who has taken both parts when he sits for the examination and obtains a pass score in only one of the two parts is deemed to have failed the examination. However, if he sits for the examination again, he would be granted an exemption from the part for which he has obtained a pass score. This exemption shall be granted provided the candidate sits for the examination again within a 3-year period from the date of result. With the exemption, he would only need to take the part of the examination for which he did not obtain a pass score. No exemption shall be granted if he sits for the examination again after the exemption period, in which case he is required to take both Parts 1 and 2.

- (c) Examination results will be mailed to the candidates within twelve weeks after the examination.

10 EXAMINATION APPEALS

A candidate who has failed the examination may submit a written appeal to review his performance. The appeal is to be received by PEB within 2 weeks after date of results and late appeals would not be considered. The result of the appeal/review will be sent by written mail to the appeal candidate. The appeal candidate would not be able to review his examination paper.

11 REVIEW COURSES

The Board does not endorse any review course or material provided as study aids.

12 REFUND OF FEES

Where an applicant who has been accepted is unable to sit for the examination subsequently, the Board may, at its discretion, refund \$150 to the applicant if the applicant submits a medical certificate by mail within 2 weeks after the examination. There will be no refund if the applicant sends a scanned copy of medical certificate via email.

13 REQUEST FOR ACCOMODATION

A candidate who has disabilities may submit a written request for accommodation. The request is to be received by PEB not later than 6 weeks before the date of examination and late request would not be considered. PEB's decision will be conveyed to the applicant by written mail not later than one week before the examination date.

Annex A: FORMAT, SYLLABUS AND SAMPLE QUESTIONS

I Practice of Professional Engineering Examination Part 1 (Common)

Professional conduct and ethics are important areas because most of the disciplinary actions taken by the Professional Engineers Board are in the area of ethics and not technical matters. Professionalism and ethics are closely related and inseparably bound as professional status and recognition are based on public interest. A professional engineer's judgment and decisions can have great impact on public health and safety. He is expected to uphold the dignity, standing and reputation of the profession. He shall practise ethically in relation to his clients, employers, fellow professionals and the public at large.

Format

This is a common paper which has two sections on the Professional Engineers Act and Professional Conduct and Ethics. The paper comprises 10 multiple choice questions (MCQs) and 5 essay type questions based on hypothetical case studies. The candidates must answer all the 10 compulsory MCQs (25 marks) and can choose to answer any 3 out of the 5 essay questions (75 marks) during the 2 hours 10 mins examination period.

Syllabus

The paper will focus on the latest revisions of the following Professional Engineers Act and Rules:

- Professional Engineers Act
- Professional Engineers (Code of Professional Conduct and Ethics) Rules
- Professional Engineers Rules

References will also be made to past disciplinary actions taken by the Professional Engineers Board arising from complaints against professional engineers.

Questions will be set to test the candidates' understanding and interpretation of the provisions in the act and rules as well as how they will tackle hypothetical cases involving the clients, the employers, fellow professionals and the public at large.

Sample Questions From Past Year Papers for Practice of Professional Engineering Examination Part 1 (Common)

Section A - Answer 10 Multiple Choice Questions – each at 2.5 marks (COMPULSORY)

- 1 Under what circumstances shall a professional engineer advise the client to engage the services of experts and specialists?
- (a) The professional engineer shall give the advice when in his opinion and judgment such services are in the interest of his client.
 - (b) The professional engineer shall give the advice when he feels such services will pass the responsibility to others.
 - (c) The professional engineer shall give the advice when he can indirectly benefit from the appointment of experts and specialists.
 - (d) The professional engineer shall give the advice when he considers that in doing so the cost input of his company will be reduced.
- 2 A professional engineer may publicise his practice. However, in doing so, the professional engineer shall ensure that the publicity —
- (a) contains information that is related to all the projects undertaken by him or his company but without the consent of the clients.
 - (b) contains only information beneficial to his business even though it is likely to diminish public confidence in the engineering profession or to otherwise bring the profession into disrepute.
 - (c) contains only justifiable claims to expertise or specialization; makes no reference to past project information which constitutes a breach of confidentiality to the client; and does not compare or criticise the quality of services provided by any other professional engineer or allied professional.
 - (d) contains information with material facts even if it may create an unjustified expectation about the results that can be achieved by him.
- 3 Engineer A provides design, plans and specifications for a commercial building to Developer P who submits them to the authority for approval but fails to pay Engineer A for the work performed. Thereafter, Developer P asks Engineer B to review, endorse and resubmit the plans to the authority for approval. Shall Engineer B agree to undertake the project?
- (a) Engineer B shall not agree to undertake the project as he has an ethical obligation to recognise and give credit to the creative works of other engineers.
 - (b) Engineer B shall agree to undertake the project as long as Engineer A does not complain.

-
- (c) Engineer B shall agree to undertake the project as Engineer A does not know.
- (d) Engineer B shall agree to undertake the project as he is employed by the Developer.
- 4 Engineer C comes from overseas and is not a registered professional engineer in Singapore. If he uses the abbreviation "Er." or "Engr" as a title before his name in Singapore, he is guilty of an offence and will be liable on conviction to —
- (a) a fine not exceeding \$2,000 and, in the case of a second or subsequent offence, to a fine not exceeding \$5,000.
- (b) a fine not exceeding \$10,000 or to imprisonment for a term not exceeding 6 months or to both.
- (c) a fine not exceeding \$5,000 and, in the case of a second or subsequent offence, to a fine not exceeding \$10,000 or to imprisonment for a term not exceeding 6 months or to both.
- (d) a fine not exceeding \$10,000 and, in the case of a second or subsequent offence, to a fine not exceeding \$20,000.
- 5 Engineer D is a Professional Engineer specialising in structural engineering design and has just inherited a plot of land from his uncle. He plans to build 6 units of terrace houses on the plot of land and engages an architect to proceed with the design. He intends to play the role of structural engineer himself. Is it in order for Engineer D to provide structural design for his own housing project?
- (a) It is in order for Engineer D to provide structural design for the project since he is a qualified structural PE.
- (b) It is in order for Engineer D to provide structural design for the project since he can save cost.
- (c) It is not in order for Engineer D to provide structural design for the project since other structural engineers will be deprived a chance to get involved.
- (d) It is not in order for Engineer D to provide structural design for the project since he is acting as a housing developer as well.

Section B - Answer 3 Out Of 5 Essay Questions (each at 25 marks)

Question 1

Engineer A, on behalf of the engineering firm of which he is a principal, submitted a statement of qualifications to a developer for a mega project.

In due course he was notified that his firm was on the "short list" for consideration along with several other firms, but it was indicated to him that his firm did not appear to have qualifications in some specialised aspects of the requirements, and that it might be advisable for the firm to consider a joint venture with another firm with such capabilities.

Engineer A thereupon contacted Engineer B, a principal of a firm with the background required for the specialised requirements, and inquired if Engineer B's firm would be interested in a joint venture if Engineer A was awarded the job. Engineer B's firm responded in the affirmative.

Thereafter, Engineer C, a principal in a firm which was also on the "short list," contacted Engineer B and indicated the same requirement for a joint venture for specialised services, and also asked if B's firm would be willing to engage in a joint venture if the C's firm was selected for the assignment. Engineer B also responded in the affirmative to Engineer C but did not notify Engineer A of his response to Engineer C.

Is it ethical for Engineer B to agree to participate in a joint venture arrangement with more than one of the several since he did not make a full disclosure to all of the firms?

Discuss the issues and comment on Engineer B's conduct with reference to relevant sections of the Professional Conduct and Ethics rules where applicable.

Question 2

Engineer A was retained by an architect to provide mechanical engineering services in connection with the design of an office building. Engineer A performed his services and thereafter a dispute arose between Engineer A and the architect as to Engineer A's compensation for his services. The issue was never resolved.

Several months later, the owner, who retained the architect on the project, requested that Engineer A provide him with a copy of the air-conditioning drawings in order to perform certain work on the building project which did not involve issues of safety or health. The owner offered to pay Engineer A the cost of reproduction and any administrative staff costs and to mediate the dispute between Engineer A and the architect. Engineer A refused to provide the owner with a copy of the drawings and declined owner's offer to mediate the dispute.

Was it ethical for Engineer A to refuse to provide the owner with a copy of the drawings and to decline owner's offer to mediate the dispute between Engineer A and the architect?

Discuss the issues and comment on Engineer A's conduct with reference to relevant sections of the Professional Conduct and Ethics rules where applicable.

Question 3

Engineer A was employed by an transportation agency to supervise and inspect the signals and communication systems of a public transportation system. The systems were supplied and installed by Company B under a design-and-build contract. Close to the completion of the project, in one of his site inspection rounds, Engineer A discovered that part of the signals cables installed were undersized, untidy and would likely lead to failure in the train signals.

He called for a meeting with the agency's management and Company B's representatives. The representatives disputed Engineer A's claim and argued that as the systems were part of a design-and-build package, Engineer A did not have the right to question what Company B did. Engineer A considered that following the discussions at the meeting initiated by him, he had fulfilled his duties in informing the agency's management and Company B's representatives even though his opinions were ignored. He then left the matter as it was and took no further follow-up actions.

Discuss the issues and comment on Engineer A's conduct with reference to relevant sections of the Professional Conduct and Ethics rules where applicable.

II Practice of Professional Engineering Examination Part 2 (Civil)

The paper aims to examine the candidates on their proficiency in the practice of civil/structural engineering at a professional level. Candidates are expected to have a good working knowledge and experience of civil/structural engineering design and practices in Singapore. In particular knowledge is required in the areas of regulatory framework, submission and approval procedures, statutory acts and regulations, practices guidelines and codes of practice.

The examination will place emphasis on the Professional Engineer's role in building projects in the local context either acting as the Qualified Person for the project or Professional Engineer for the civil and structural engineering works.

Format

This is a 4 hours 10 mins paper and a candidate is required to answer 1 compulsory question covering the design of concrete and steel structures and choose 4 out of 7 questions covering areas of design, codes of practice, acts and regulations, submission/approval procedures & site supervision. The candidates may bring along their own reference materials and calculators as necessary.

(Note: For PPE 2024 Part 2 Civil, only answers based on Eurocodes will be accepted. Answers based on Singapore/British Standards will not be accepted.)

Syllabus

The list of reference literature, codes, acts, regulations, etc., appended below is meant as a guide and is not exhaustive. The latest Acts and Regulations, Publications and Civil Engineering Codes /Standards will apply.

- **Acts and Regulations**
 - Professional Engineers Act and Regulations
 - Building Control Act and Regulations
- **Publications**
 - **SCDF**
 - Code of Practice for Fire Precautions in Buildings
 - Handbook on Fire Precautions in Buildings
 - FSSD Fire Safety Handbooks
 - **LTA**
 - Guidelines & Publications on Rapid Transit Systems
 - Building Works & Restricted Activities in Railway Protection Zone

- Street Proposals
- Vehicle Parking
- Other Guidelines and Standards

- **NEA**
 - Code of Practice on Environmental Health
 - Code of Practice on Pollution Control

- **PUB**
 - Code of Practice on Surface Water Drainage
 - Standard Specifications for Drainage Works
 - Code of Practice on Sewerage and Sanitary Works
 - Sewerage and Drainage Standard Drawings

- **NParks**
 - Procedures and Guidelines for Plan Submissions

- **MOM**
 - Workplace Safety & Health Act and Subsidiary Legislations

- **BCA**
 - Guidelines and Handbooks on Civil Defence Shelters
 - Code of Practice on Buildable Design

- **Civil Engineering Codes/Standards**
 - Codes and Standards under Building Control Act and Regulations
 - Codes and Standards for Roads and Transit Systems to LTA's Requirements

Sample Questions From Past Year Papers for Practice of Professional Engineering Examination Part 2 (Civil)**Section 1- Question 1 (20 marks) is COMPULSORY**

Question 1

You are the appointed Engineer for a development of a workshop with offices. Please refer to Figure Q1-1 for floor plan. All dimensions on plan in millimetres unless otherwise stated.

Below are the Client's specifications: -

- A column-free workshop area with overhead crane
- Two doors 11m wide by 7m high
- Pitched roof
- Provision of lights at roof area
- Maximum height of workshop limited to 15m
- Maximum spacing of perimeter columns at 10m
- Office areas have two levels with minimum floor-to-floor at 4m
- Overall depth of the crane 1.5m with clear height 8m from floor to underside of crane beam

| Imposed loadings | |
|-------------------------|------------------------|
| Roof | 0.75 kN/m ² |
| Office floors | 5.0 kN/m ² |
| Factory floor | 50.0 kN/m ² |
| Crane weight | 200 kN |
| Hoist unit | 20 kN |

Question 1 (Cont'd)

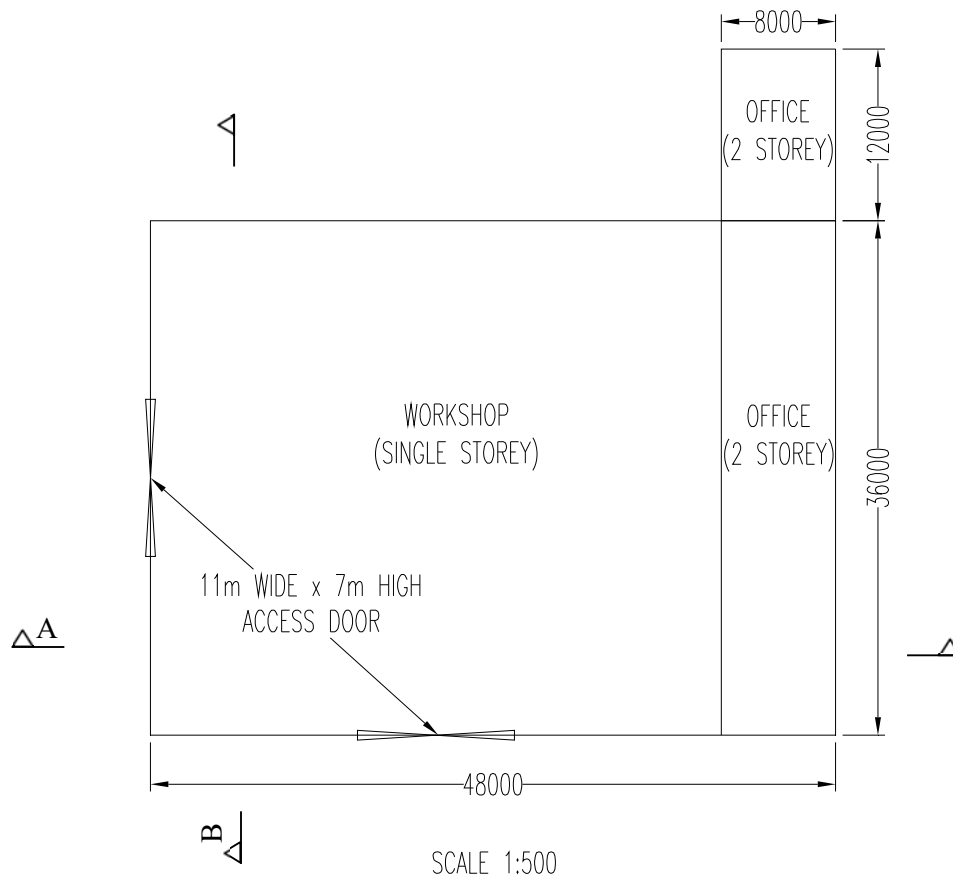

Figure Q1-1

- Produce a viable structural scheme for the proposed building. The scheme should cover the roof plan and two sections, A-A and B-B, drawn to scale. The overhead crane shall be included in your section.
- Compute the ultimate vertical action on a typical perimeter column for section A-A. The columns will be supported by pad footings and the ground floor is a non-suspended slab. Assume that the vertical load due to wind is 25 kN.
- List the types of horizontal load to be considered for the column design. No calculation is required.

Section 2 - Answer 4 Out Of 7 Questions (each at 20 marks)

Question 2

Figure Q2-1 illustrates a proposed typical floor layout of a 8-storey hotel development. The site is underlain with deep Marine Clay and the building will be supported on piles. The Client's brief calls for the following design requirements:

- (i) Floor-to-floor height is 3.5m
 - (ii) Framing system must provide reasonable flexibility of future changes to room layout
 - (iii) Light weight dry partitions for non-structural walls
 - (iv) Structure should be buildable
 - (v) Beam is not permitted to pass through the corridor due to M&E services
- (a) Propose design imposed loads for the various floor usage as indicated on the plan.
- (b) Identify the lateral loads that the building structure has to be designed for.
- (c) Propose a structural concept framing plan for the layout, considering all the Client's design requirements. The framing system must be able to support gravity loads and resist lateral loads.
- (i) Indicate preliminary sizes of the structural elements.
 - (ii) Explain the basis of your proposal and the load paths.

For the purpose of preliminary sizing, you may assume a superimposed permanent action of 1.8 kN/m^2 for finishes/M&E services and a variable action of 1.0 kN/m^2 for internal partitions, respectively.

- (d) The vertical elements supporting the hotel floors are to be transferred at 2nd Storey due to planning requirements at the 1st Storey. The outline of the 2nd Storey plan is shown in Figure Q2-2. Only twelve (12) circular columns are permitted at 1st Storey to support the transfer structure. The lift and stair cores go down to the foundation.
- (i) Propose an efficient framing plan of the transfer structure and indicate the locations of the 12 columns for the 1st Storey.
 - (ii) Indicate preliminary sizes of the transfer structure and explain the rationale of your proposal.

Question 2 (Cont'd)

Hint: Review Questions 2(c) and 2(d) together to offer a holistic solution. No calculation is required. Provide clear sketch plans to illustrate your intent in the 2 page answer sheet provided and tie with the answer booklet.

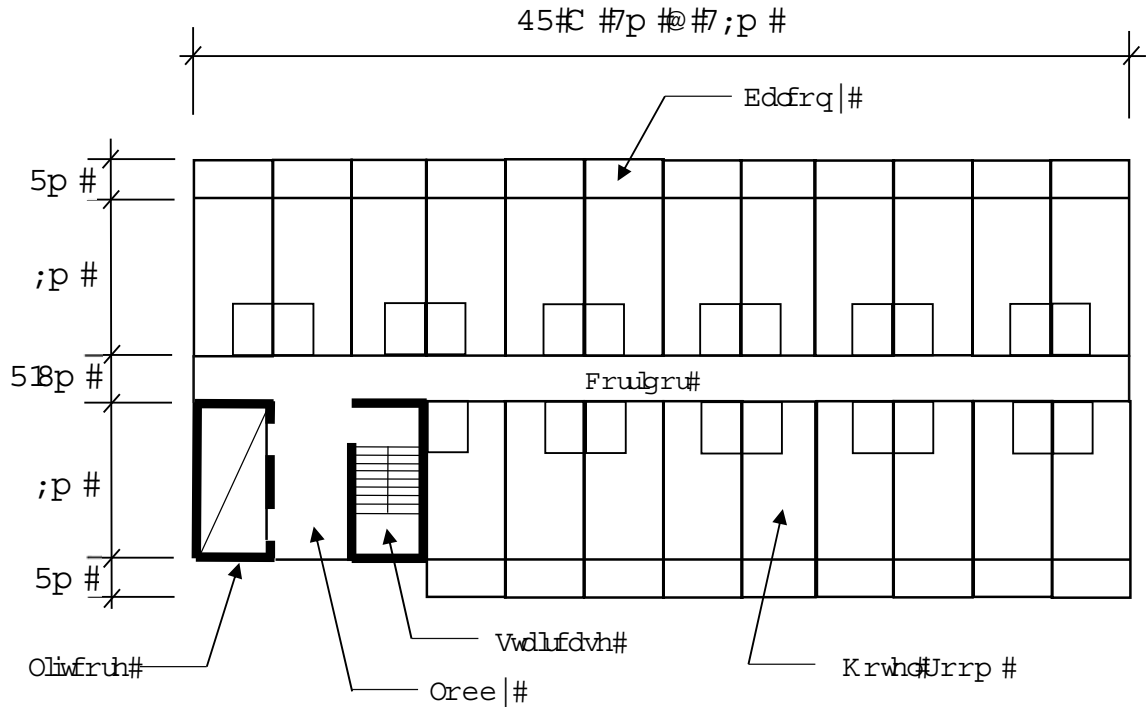

Figure Q2-1

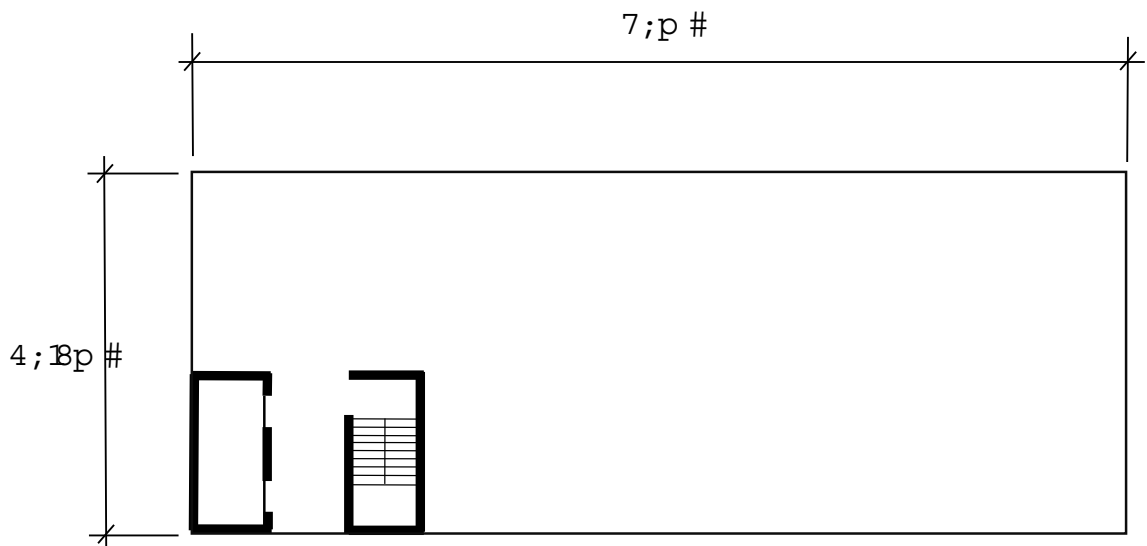

Figure Q2-2

Question 3

A new staircase is to be installed to connect two office floors in an existing high-rise building. The staircase will be made of steelworks due to weight consideration and construction constraints. The staircase is typically of dog-leg type without support at the mid-landing level as shown in Figure Q3-1 to Figure Q3-4.

The floor slab element consists of one-way precast pre-stressed concrete plank with in-situ concrete topping spanning between post-tensioned beams. The beams span from external columns to the central concrete core. To accommodate the proposed staircase, an opening is created at the upper floor. Three framing beams will be installed to strengthen the existing floor slab and to provide support to the staircase.

The staircase rests directly on the lower floor slab

- (a) The four support points of the staircase are designed as fixed connections as shown in Figure Q3-5 and Figure Q3-6.

Discuss whether these four support points could be designed as pinned connections. Elaborate your rationale and advantages of each connection type with respect to the connection detailing, behaviour of the staircase and impact to the structural elements of the system.

- (b) Would you agree if the contractor proposes to change the SHS to a H-Section with higher moment and shear capacities for the three framing beams at the upper floor? Elaborate your answer.
- (c) What are the serviceability limit states that need to be considered and checked for the staircase? State the serviceability criteria.
- (d) Explain whether you need to check in-plane stress and other effects of loads for the upper and lower floor slabs imposed by the staircase. Using sketches, suggest a way to strengthen the lower floor slab.
- (e) Assuming structural analysis has been carried out with various ultimate load combinations to determine the effects of loads on all the components of the staircase,
- List down the effects of loads that would need to be considered in the design for the lower stringer beam.
 - List down the design procedure for the lower stringer beam according to SS EN 1993.

Question 3 (Cont'd)

Note for Figure Q3-1 and Figure Q3-2:

- SB1 and SB4 denote 300 x 300 x 16 SHS, SB2 denotes 200 x 200 x 16 SHS
- All steel plates shall be Grade S355JR hot rolled to BS EN 10025
- All hollow sections shall be Grade S355J0H hot finished to BS EN 10210
- All Steel materials shall be Class 1 to BCA BC1:2012

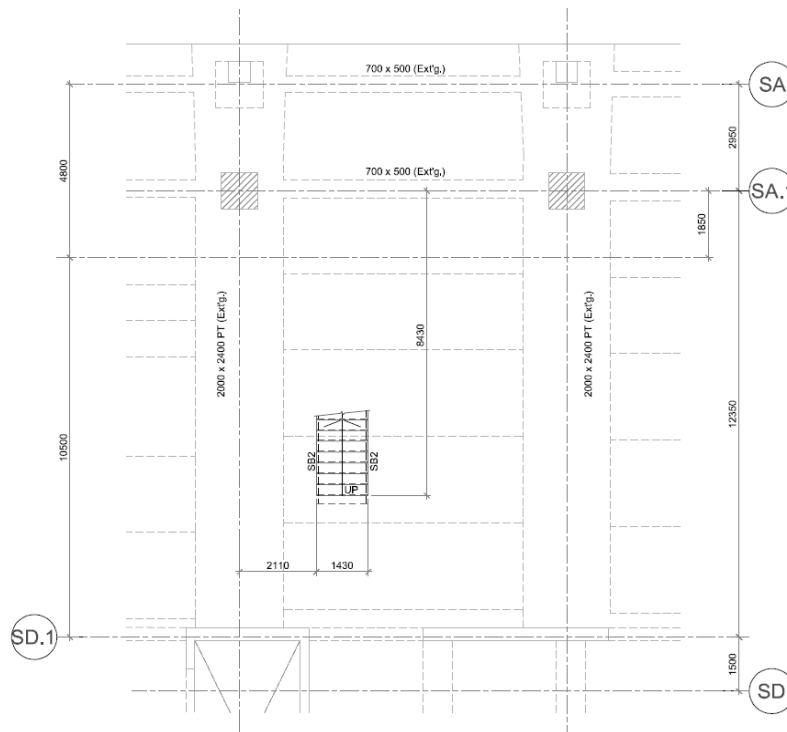

Figure Q3-1 Lower Floor Plan

Question 3 (Cont'd)

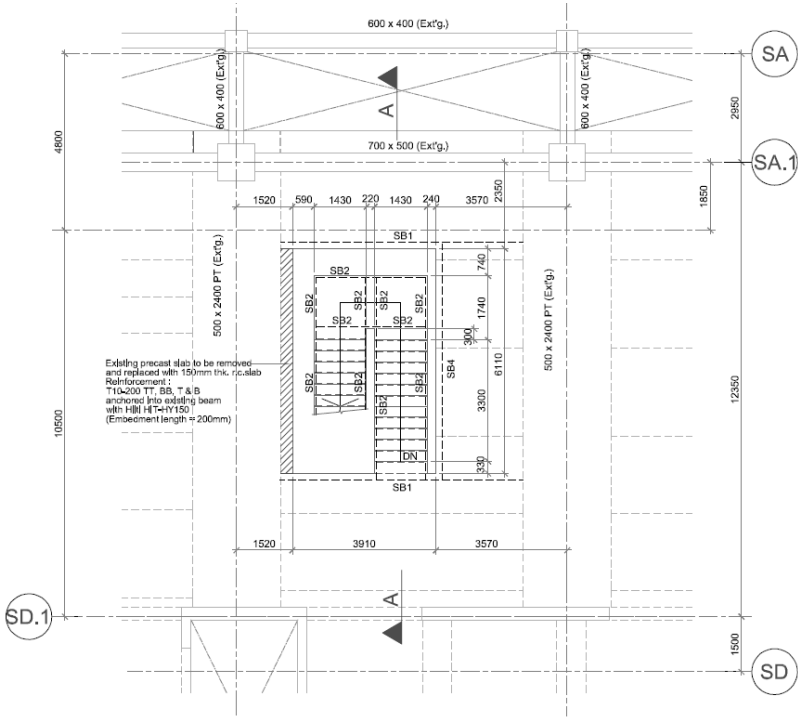

Figure Q3-2 Upper Floor Plan

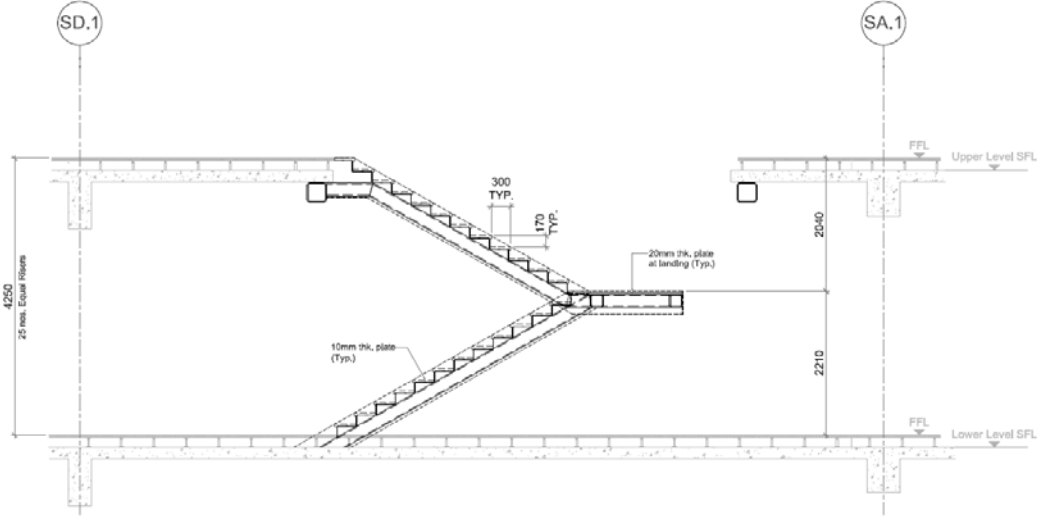

Figure Q3-3 Section A-A

Question 3 (Cont'd)

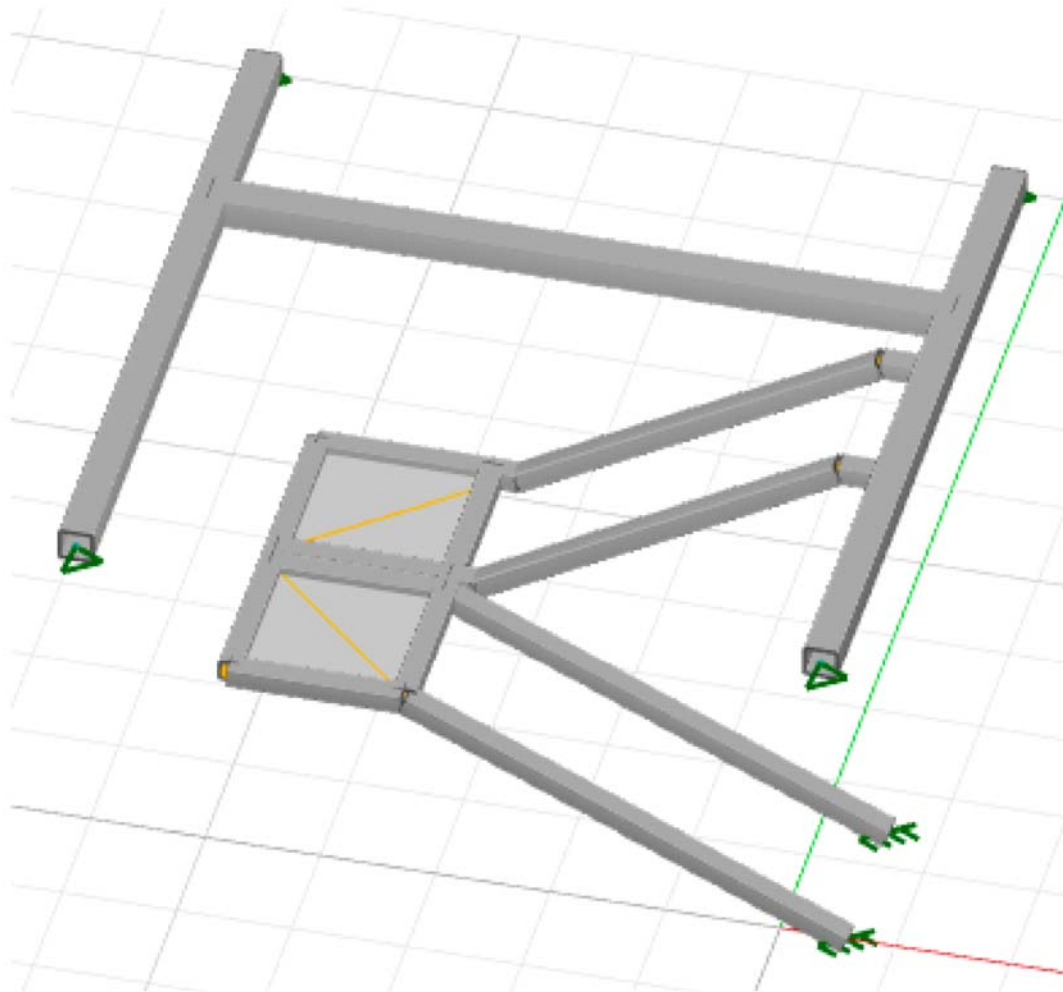

Figure Q3-4 Isometric view of the dog-leg staircase

Question 4

Your client's neighbor has a structure which encroaches into his premises (Figure Q7). He has obtained the Court's permission to demolish the encroachment on his land. You are required to submit the necessary Structural Plans [ST] to BCA for approval. The ST submission should include provisions for demolishing the portion of the structure encroaching on your client's land.

You may assume the following:

The density of the soil is 18 kN/m^3

Surcharge load is 10 kN/m^2

The water table is constant at 1.3 m below ground level

The coefficient for concrete cast on clayey sand is 0.4

The coefficient of active earth pressure for clayey sand is 0.3

- (a) Show the approach you would take to ascertain the safety of the remaining structure after removal of the encroaching portion.
- (b) If you need to strengthen the partially demolished structure and your client insists that any strengthening works should be done only on his neighbor's land, what would you recommend?

Question 4 (Cont'd)

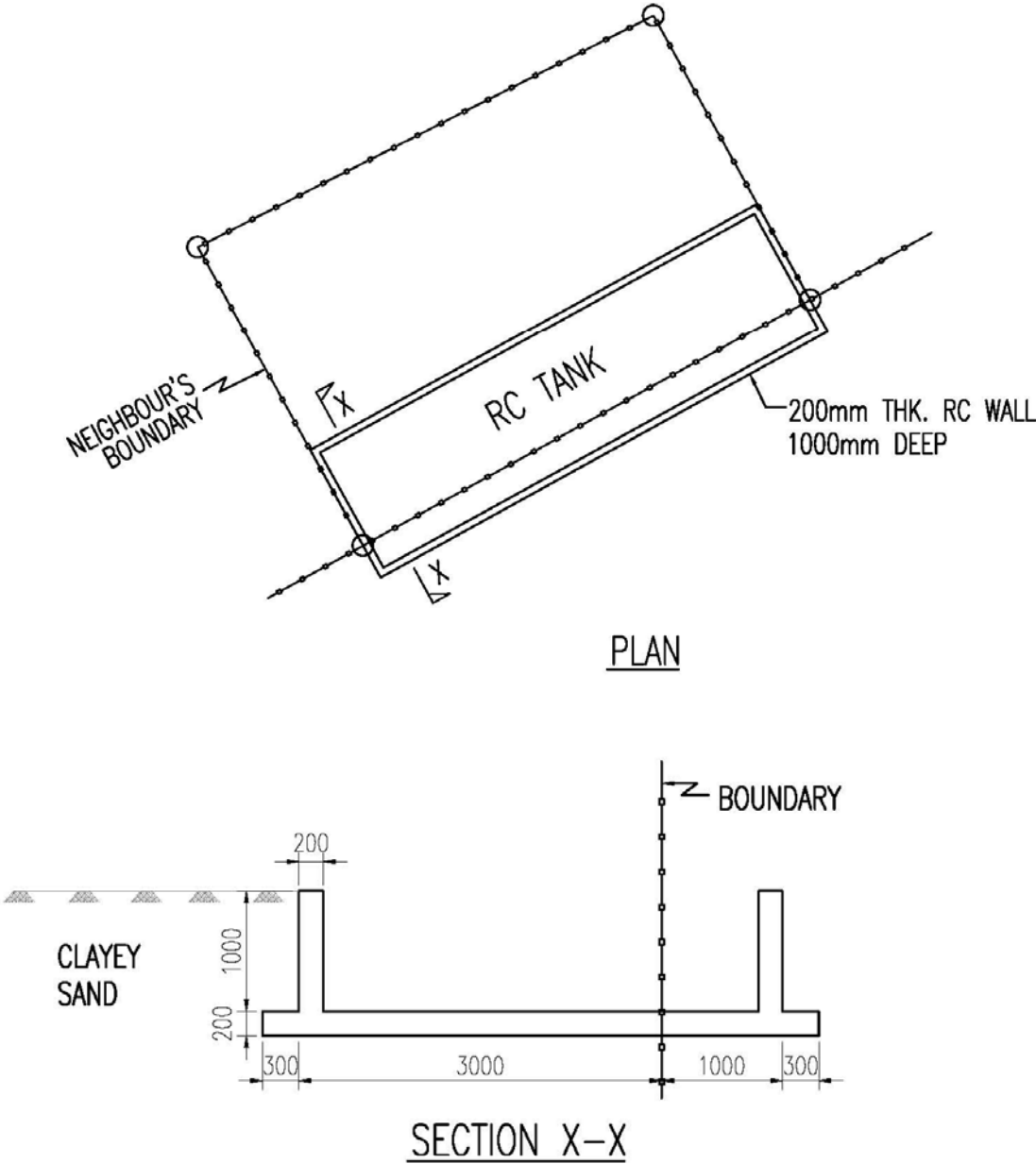

Figure Q4

III Practice of Professional Engineering Examination Part 2 (Electrical)

The paper aims to examine the candidates on their proficiency in the practice of electrical engineering at a professional level. Candidates are expected to have a good working knowledge and experience of electrical engineering design and practices in Singapore. In particular knowledge is required in the areas of regulatory framework, submission and approval procedures, statutory acts and regulations, practices guidelines and codes of practice.

The examination will place emphasis on the Professional Engineer's role in building projects in the local context in relation to electrical engineering works.

Format

This is a 4 hours 10 mins paper that examines candidates on technical competency and understanding of standards and codes that are applicable in Singapore for the discipline of electrical engineering.

The paper consists of 2 Sections and 8 questions. Candidates must answer questions in both sections (Section 1 and Section 2). Section 1 consists of a compulsory question on SS 638, statutory acts and regulations. Candidate is required to answer this compulsory question. Section 2 consists of 7 questions. Candidates shall choose to answer 4 out of 7 questions. The latest Acts and Regulations, Publications and Engineering Codes /Standards will apply.

Syllabus

- **Codes of Practice**
 - SS 638: Code of practice for electrical installations
 - SS 626: Code of practice for design, installation and maintenance of escalators and moving walks
 - SS 650 - 1 : Code of practice for temporary electrical installations - Construction and building sites
 - SS 650 - 2 : Code of practice for temporary electrical installations - Festive lighting, trade-fairs, mini-fairs and exhibition sites
 - CP 88 - 3 : Code of practice for temporary electrical installations - Shipbuilding and ship-repairing yards
 - SS 530: Code of practice for energy efficiency standard for building services and equipment.
 - SS 531-1: Code of practice for lighting of work places – Indoor.

- SS 531-2: Code of practice for lighting of work places – Outdoor.
- SS 531-3: Code of practice for lighting of work places - Lighting requirements for safety and security of outdoor work places.
- SS 532: Code of practice for the storage of flammable liquids.
- SS 535: Installation, operation, maintenance, performance and construction requirements of mains failure and standby generating system.
- SS 538: Code of practice for maintenance of electrical equipment of electrical installations.
- SS 546: Emergency voice communication system in building.
- SS 550: Installation, operation and maintenance of electric passengers and goods lifts.
- SS 551: Code of practice for earthing.
- SS 555-1 : Code of practice for protection against lightning – General requirement.
- SS 555-2 : Code of practice for protection against lightning – Risk management.
- SS 555-3 : Code of practice for protection against lightning – Physical damage to structures and life hazard.
- SS 555-4 : Code of practice for protection against lightning – Electrical and electronic systems within structures.
- SS 558: Code of practice for construction, installation, operation and maintenance of intruder alarm systems.
- SS 563-1: Code of practice for the design, installation and maintenance of emergency lighting and power supply systems in buildings. Part 1 : Emergency lighting.
- SS 563-2: Code of practice for the design, installation and maintenance of emergency lighting and power supply systems in buildings. Part 2 : Installation requirements and maintenance procedures.
- SS 564-1: Green data centres - Part 1 : Energy and environmental management systems

- SS 564-2: Green data centres - Part 2 : Guidance for energy and environmental management systems
- SS 576: Code of practice for earthworks in the vicinity of electricity cables.
- SS 601: Code of practice for maintenance of grid-tied solar photovoltaic (PV) power supply system
- SS 645: Code of practice for the installation and servicing of electrical fire alarm systems
- TR 25: Technical Reference for electric vehicle charging system
- TR 100: Technical Reference for Floating photovoltaic power plants - Design guidelines and recommendations
- Electricity Act
- Electricity (Electrical Installations) Regulations
- Handbook for Application of Installation Licence, published by EMA
- Fire Code & Fire Code Handbook
- BCA Green Mark Assessment Criteria published by BCA
- Code on Accessibility in the Built Environment published by BCA
- Handbook for solar photovoltaic system (PV) Systems, published by BCA and EMA
- How to Apply for Electricity Connection, published by SP Group
- Code of Practice for Info-communication Facilities in Buildings (COPIF) published by IMDA
- Transmission Code
- **Electrical Power Supplies, Tariffs and Design**
 - Electricity market
 - Generation, transmission and distribution in Singapore
 - Electricity bill calculation for HT and LT consumers

- Design of electrical installations
 - Load estimation
 - Power factor correction
 - Power quality and power system harmonics
 - Consumer Substation, Switchboards and Switchgears
 - Maintenance of electrical equipment, switchgears and cables
 - Design for energy efficiency and sustainability
- **Lighting requirement for workplace, indoor and outdoor**
 - Visual needs for safety and security
 - Determine the lighting requirements for indoor and outdoor work places.
- **Energy efficiency and accessibility requirement for buildings**
 - Minimum energy-efficiency requirements for new installation and replacement of systems and equipment in buildings
 - Replacement of components of systems and equipment in buildings
 - Criteria for determining compliance with energy efficiency in building with regards to air-conditioning and heat rejection equipment, water heaters, motor drives and lighting used in buildings.
 - Requirement and guidelines for buildings to be designed or retrofitted to provide accessibility and safety to persons with disabilities and families with young children.
- **Protection for Safety**
 - Measures in protection against electric shock (basic and fault)
 - Principle of operation of protective devices
 - Maximum demand and diversity factors
 - Protection against over-current and short circuits

- Protective devices and circuit conductors
- Discrimination in protection of electrical circuits
- **Cables, Busways, and Distribution Boards**
 - Type and characteristic of cables
 - Method of installation
 - Sizing of conduit and trunking
 - Factors affecting the current carrying capacity of cables
 - Sizing of cables and busways for use under different types of conditions
 - Connected load, maximum demands and circuit breakers ratings for a electrical distribution board
- **Earthing**
 - Purpose of earthing
 - Methods of earthing
 - Earth fault loop impedance and earth fault current
 - Suitable sizes of circuit protective conductor
 - Testing of earthing
- **Lightning Protection Systems**
 - Rolling sphere technique of determining zones of protection
 - Spacing of air terminations and types of air termination
 - Down conductors for building below 45 m and those exceeding 45 m
 - Earth electrodes, earth resistance values and hazards of a rise in ground potential caused by lightning strike
 - Selection of appropriate materials and installation methods
 - Prevention of side flashing

- Design requirement of complete lightning protection system
- Transients and surge suppression
- Effect of lightning on system and structure
- Source and type of damages due to lightning
- Risk assessment aspect in lightning protection
- **Emergency Lighting**
 - Exit and emergency lighting requirements for evacuation of occupants
 - Types of back-up power supplies
 - Exit and directional Signs
- **Standby Power Generator System**
 - Types of essential and critical loads
 - Sizing of generator with considerations for maximum demand of essential load, transient or motor starting loads and voltage dip
 - Voltage regulation and its effects on generator sizing
 - Protection for alternator and prime mover
 - Installation of standby generator system including day-tank, battery and charger, fuel supply, engine cooling system, plant room ventilation, exhaust and fresh air intake, control and instrumentation panel and automatic transfer switch.
 - Underground fuel storage system
 - Grounding/Earthing arrangement
 - Maintenance
- **Automatic Fire Alarm System**
 - Requirement for automatic and manual fire detection system and purpose of compartmentation as required by the Fire Code

- Interaction with other building services such as emergency voice communication system, lifts, AHUs, pressurization fans and auto-doors during alarm activation
- **Emergency Voice Communication System**
 - Requirements for public address system for building above 24 m but less than 60 m
 - Requirements for emergency voice communication for building above 60 m
 - Requirements for fireman intercom
- **Inspection, Testing and Common Violation In Electrical Installation**
 - Mandatory requirements for inspection and testing of electrical installation prior to energisation of electrical supply
 - Types of test instruments and standard methods of testing

Sample Questions From Past Year Papers for Practice of Professional Engineering Examination Part 2 (Electrical)

Section 1 - Question 1 (28 marks) is COMPULSORY

Question 1

- (a) Explain the difference and purpose of bonding and earthing as required for an electrical installation in Singapore.

You are checking the lightning protection system for a building for compliance to the new code, what is the minimum size of stranded copper bonding conductor allowed to connect the non-ferrous connector point to the earth termination system?

- (b) You are the LEW responsible for the electrical installation in a newly built mixed development. The main switchboard is ready for turn on. Identify the certificate(s) to be submitted to SP Services Ltd (SPS) when you request for an energisation appointment.
- (c) An electrical installation with an approved load of 1000 KVA is taking direct supply from PowerGrid's network. The low voltage main switchboard (MSB) with air circuit breaker (ACB) had passed the factory acceptance test and was delivered to site; feeder cables were laid and terminated to the MSB. Identify the tests to be carried out on site before requesting for the turn-on by SP Services Ltd (SPS).
- (d) Explain the purpose of the primary injection test.
- (e) Refer to the distribution board shown in Figure Q1(e). A new load, an air handling unit (AHU) rated at 11 kW 3-phase 400V at 0.8 pf, will be added to the distribution board.
- (i) Is there a need to upgrade the incoming breaker size and the bus bar ratings of the distribution board? State the reason(s) for your answer.
- (ii) Determine the current rating of the MCB and the cable size for the new AHU. Assume that the cable length from the distribution board to the new AHU is 20m and the permitted Line-Line voltage drop is 8V.
- (iii) Is there a change in the short-circuit rating of the MCCB in the distribution board when the new load is added? State the reasons for your answer.

Question 1 (Cont'd)

- (iv) How would the LEW in-charge of the operation and maintenance of the electrical installation isolate the distribution board to make it safe for the modification works to be carried out? Elaborate on the procedures and safety measures to be taken before physical works on the distribution board can commence.

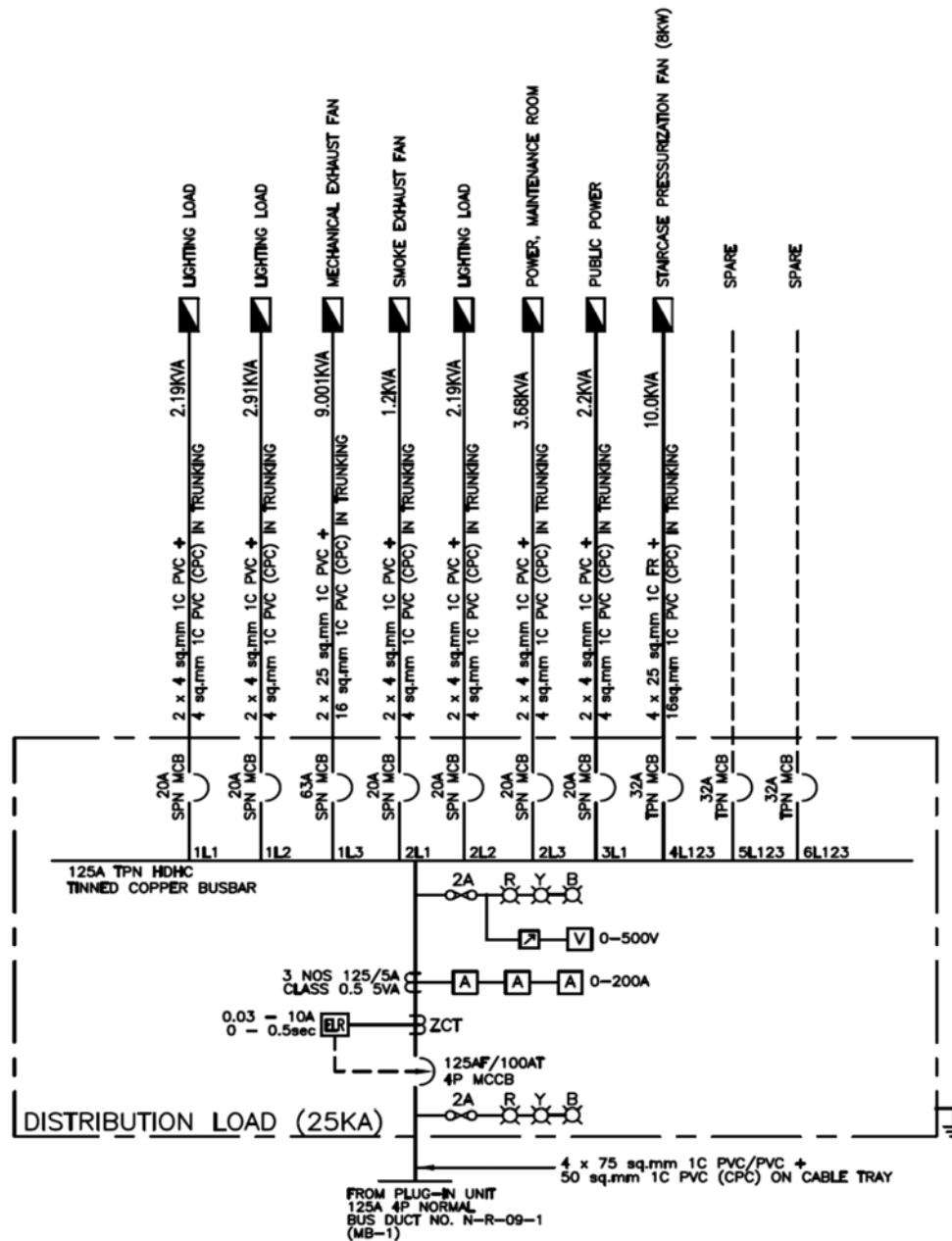

Figure Q1(e)

Section 2 – Answer 4 Out Of 7 Questions (each at 18 marks)

Question 2

- (a) You are asked to design an installation where electronic system will be installed and required to comply with electromagnetic compatibility (EMC) requirement. Identify the three criteria for your design?
- (b) Figure Q2(b) shows the basic decomposition of a typical EMC coupling problem where EMC is concerned with the generation, transmission and reception of electromagnetic energy. What are the three ways to prevent unintended interference?

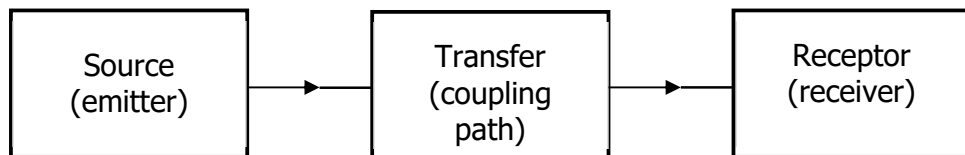

Figure Q2(b)

- (c) A vertical electrical riser housed inside an office/commercial complex is radiating electromagnetic field (EMF) as measured and indicated in Figure Q2(c). Explain how to remove or reduce the radiated EMF and to protect the occupants from this exposure?

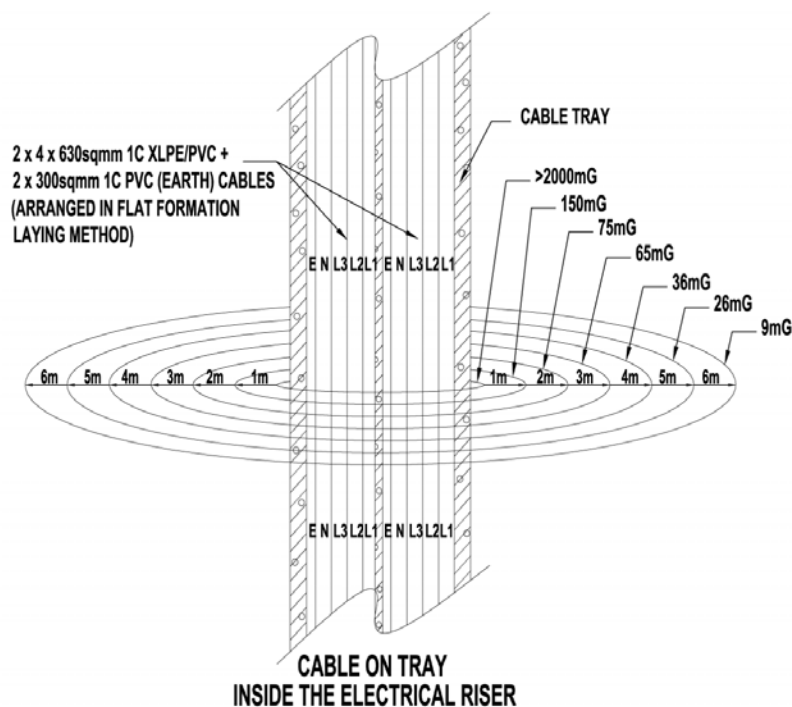

Figure Q2(c)

Question 2 (Cont'd)

- (d) (i) State the main purpose of the lightning protection system.
- (ii) Explain how the main purpose stated in above (i) can be achieved.
- (iii) Explain how to reduce the dangerous side-flashes for a building?

Question 3

- (a) Before work can commence on a high voltage switchboard, what are the 5 essential steps that need to be carried out to ensure the safety of the workers? Assume that you can only shut down half of the switchboard.
- (b) With the aid of a diagram, describe the protection requirements of the incoming panel of a 22 kV supply. You should include the type, rating and accuracy class of various devices where appropriate.
- (c) A 22kV/400V 2-MVA transformer is connected directly to the "incoming mains" air circuit breaker of a LV switchboard. The 22 kV cable is protected by an IDMTL overcurrent relay R1 which is connected to 100/5A current transformers. R1 is set at 50% plug setting and time multiplier at 0.3. The protection on the LV side is an IDMTL overcurrent relay R2 which is connected to 3000/5A current transformers. Both the relays R1 and R2 have the same time-current characteristic which is given by:

$$t = 0.14 / (M^{0.02} - 1) \text{ secs (for Time Multiplier = 1)}$$

where M = Plug Setting Multiplier

The symmetrical fault current at the 400-V switchboard is 36,000 A. Determine a suitable plug setting and a suitable time multiplier for relay R2 if the time discrimination between the two relays R1 and R2 is 0.4 secs.

Available plug settings for the two IDMTL relays are 50%, 75%, 100%, 125%, 150%, 175% and 200%.

Assume the LV circuit breaker does not have direct-acting element.

Question 4

- (a) In your design of the electrical switchroom, you have given thoughts for future maintenance.
- (i) State the requirement for earthing resistance and extraneous conductive parts when you are conducting the handover inspection.
 - (ii) Explain and state the purpose on the requirement expected before the end of defect liability period (DLP) in the interest of your client.
- (b) A 630A, 230/400V 50 Hz switchroom distributing energy to a row of shophouses is disgusted with paper boxes and accumulated dirt over prolonged period of 3 years. The owner explained to you that the load is high only during all the festive seasons, such as mid-autumn, Deepavali, Hari Raya, and the like in Singapore. You are asked by the owner to advise the frequency of maintenance and any violation.
- (c) During a routine check on a switchboard and the stand-by generator for an electrical installation that is providing supply at 3-phase 4-wire 400/230 V 50 Hz to the mix load of a building. After you have switched over the mix load from the utility supply to the generator supply, you noticed that few lamps could be seen to flicker on its brightness; and decided to measure the voltage. The measured values were:
- L1 to L2 = 406 V
 - L2 to L3 = 400 V
 - L3 to L1 = 410 V
 - L1 to N = 140 V
 - L2 to N = 200 V
 - L3 to N = 303 V
 - N to E = 140 V

You decided to reconnect the mix load back to the utility supply. Those lamps that flickered, do not flicker any more. You measured the voltage again and the values were:

- L1 to L2 = 405 V
 - L2 to L3 = 401 V
 - L3 to L1 = 408 V
 - L1 to N = 234 V
 - L2 to N = 230 V
 - L3 to N = 238 V
 - N to E = 3 V
- (i) From the results, explain the phenomenon that the lamp flickers.
 - (ii) What do you deduce from this result and how would you troubleshoot?

Question 5

- (a) You are the designer of a condominium project and a lift is required to be provided between basement 1 & 2 carparks and the 1st storey of the residential block. The total travel distance of these 3 landings is 6.8m and you have advised the client to install a lift complying with SS 550 instead of a platform lift, as it has safety features that a platform lift does not have. List 6 safety features and explain the purpose of each safety feature.
- (b) The Greenmark criteria for new residential buildings require that the energy performance and energy effectiveness of a building be evaluated.
- (i) Name 3 systems where energy performance evaluations must be carried out and give a brief description of each evaluation.
 - (ii) For the effective use of energy assessment criteria, energy efficient features are encouraged. Name any 3 such energy efficient features.
- (c) Data centres are typically lightly occupied and notwithstanding that the lighting load is a small portion of the total load of a data centre, propose 2 methods of lighting design that will reduce the lighting energy consumption.
- (d) State 2 design considerations for an Emergency Voice Communication System to comply with the SS Code of Practice and the Fire Code with respect to:
- (i) audibility, and
 - (ii) fault monitoring.

IV Practice of Professional Engineering Examination Part 2 (Mechanical)

The paper aims to examine the candidates on their proficiency in the practice of mechanical engineering at a professional level. Candidates are expected to have a good working knowledge and experience of mechanical engineering design and practices in Singapore. In particular knowledge is required in the areas of regulatory framework, submission and approval procedures, statutory acts and regulations, practices guidelines and codes of practice.

The examination will place emphasis on the Professional Engineer's role in building projects in the local context in relation to mechanical engineering works.

Format

This is a 4 hours 10 mins paper that examines candidates on technical competency and understanding of the use and application of standards and codes that are applicable to the practice of mechanical engineering at a professional level in Singapore.

The paper consists of 2 Sections comprising a total of 8 questions. Candidates are required to answer questions in both sections (Section 1 and Section 2). Section 1 will consist of a compulsory question on principles, codes, and legislation related to general mechanical engineering practice, safety and environmental protection. Section 2 will consist of a total of 7 optional questions. Candidates may choose to answer any 4 out of the 7 questions.

Syllabus

The scope of professional engineering work covered by Professional Engineers (Mechanical) may include the following fields: -

- **Piped Services**

Cold and Hot Water Services; Sanitary Plumbing Systems within buildings; Town Gas Incoming Supply and Distribution; Liquefied Petroleum Gas (LPG) Multi-Cylinder Systems; Swimming Pool Filtration System

- **Air Conditioning & Mechanical Ventilation**

Indoor Air Quality Comfort / Environmental Control / Fire Safety Requirements

- **Fire Safety in Buildings**

Wet and Dry Rising mains/Hydrant Systems; Fire Hose reel System; Automatic Fire Sprinkler System; Fire Detection and Alarm System; Gas Flooding System

- **Lift and Hoisting Systems**

Lifting / Hoisting Equipment

- **Other Major Mechanical Systems and Services**

Boiler Plants, Calorifiers, Pressure Vessels, Pressure Piping

- **Energy Conservation for Mechanical Building Services / Buildings**

- **Relevant Codes of Practices, Standards and Acts (Based on latest applicable Codes of Practices, Standards and Acts)**

All relevant regulations, by-laws, Acts and accepted codes of practice of:-

- National Environment Agency
- Public Utilities Board
- PowerGas Ltd
- PowerGrid Ltd
- Singapore Civil Defence Force
- Ministry of Manpower
- Building and Construction Authority
- Energy Market Authority

- **Singapore Standards – Codes of Practice (Based on latest applicable Codes)**

- SS 497: Code of practice for design, safe use and maintenance of gantry cranes, overhead travelling cranes and monorail hoists
- SS 536: Code of Practice for safe use of mobile cranes
- SS 559: Code of Practice for safe use of tower cranes

-
- SS 567: Code of Practice for Factory Layout – Safety, Health and Welfare Considerations
 - SS 595: Singapore Standard for steel wire ropes for hoisting - Part 3: Code of practice for the care, inspection and maintenance of steel wire ropes for hoisting
 - SS 617: Code of practice for the lifting of persons in work platforms suspended from cranes
 - SS 532: Code of Practice for the Storage of Flammable Liquids
 - SS 597: Code of practice for bulk liquid oxygen storage installations on user premises
 - SS 636: Code of Practice for Water Services
 - CP 52: Code of Practice for Automatic Fire Sprinkler System
 - SS 530: Code of Practice for Energy Efficiency Standard for Building Services and Equipment
 - SS 553: Code of Practice For Air-Conditioning And Mechanical Ventilation In Buildings
 - SS 554: Code of practice for indoor air quality for air-conditioned buildings
 - SS 575: Code of practice for fire hydrant, rising mains and hose reel systems
 - SS 578: Code of Practice for Use and Maintenance of Portable Fire Extinguishers
 - SS 591: Code of practice for long term measurement of central chilled water system energy efficiency
 - SS 608: Code of practice for gas installation
 - CP 10: Code of Practice for The Installation and Servicing of Electrical Fire Alarm Systems
 - SS 550: Code of Practice for Installation, Operation and Maintenance of Electric Passengers and Goods Lifts.
 - SS 626: Code of practice for design, installation and maintenance of escalators and moving walks

- SS 564 - 1: Singapore Standard for Green data centres - Part 1: Energy and environmental management systems
- SS 564 - 2: Singapore Standard for Green data centres - Part 2: Guidance for energy and environmental management systems

- **Other Standards and Codes (Based on latest applicable Standards and Codes)**
 - NFPA 2001: Standard for Clean Agent Fire Extinguishing systems (FM200)
 - American Society of Mechanical Engineers codes on pressure vessels and piping
 - American Petroleum Institute codes on pressure vessels and piping
 - British Standards on pressure vessels and piping

Sample Questions From Past Year Papers for Practice of Professional Engineering Examination Part 2 (Mechanical)

Section 1 (28 marks) - Compulsory

Question 1

(All **TEN** parts in Q1 carry equal marks)

- 1.1 (a) When is pressurization required for staircases? What are the performance criteria that must be achieved in pressurization?
- (b) For duct penetrations, when are fire dampers not permitted?
- (c) Describe how you should design a mechanical ventilation system for a smoke free lobby.
- 1.2 (a) Where passenger lifts are installed in a building with manual or automatic fire alarm system as required in the code, describe how the lifts should function when the fire alarm is activated.
- (b) Also describe how the lifts should function in the event of normal power failure or interruption.
- (c) In a building without standby generator what should you provide for the safe operation of the passenger lifts in the event of main power failure or interruption?
- 1.3 Town gas is to be provided for food and beverage outlets in a new commercial building development.
- (a) What are the requirements if the gas piping is to be routed through a naturally ventilated basement car park?
- (b) Describe the interlocking system to be provided if the kitchen of a food and beverage outlet is not naturally ventilated and is located in the basement.
- (c) What are the requirements if the gas piping is routed within the false ceiling of an air conditioned corridor which is 30 m long at storey 1?
- 1.4 (a) What is hot-tapping as practiced in process plant operation?
- (b) Under what considerations can hot tapping technique be used?

- 1.5 Discuss the purpose of pressure testing? Write short notes on the following pressure testing methods:
- (a) Leak testing;
 - (b) Pneumatic testing; and
 - (c) Proof testing.
- 1.6 (a) Explain the meaning of "design point" in the design of an Ordinary Hazard sprinkler system.
- (b) A circular duct is located more than 150 mm from the wall. What is the maximum width this can be before a sprinkler must be installed underneath it?
- (c) What is the maximum distance below a non-combustible ceiling that a sprinkler may be installed?
- 1.7 (a) State the density of discharge (mm/min) for OHII design.
- (b) Explain briefly the operation of a pre-action sprinkler system.
- 1.8 In air-conditioning cooling load calculations for the purpose of sizing systems, what are the indoor and outdoor design conditions to be used? Support your answers with recommendations from the relevant code of practice.
- 1.9 In designing an air-conditioning system to handle out-gassing from furnishings and other works what provisions must be made to the system?
- 1.10 (a) What is the definition of "Factor of Safety" as associated with the use of steel wire ropes for hoisting?
- (b) What are the respective minimum Factor of Safety for stationary and running wire ropes used for winches and cranes?

Section 2 – Answer 4 Out 7 Questions (each at 18 marks)

Question 2

- (a) What are the primary objectives in maintaining swimming pool water in a safe and pleasant condition?
- (b) Calculate the minimum volume of a storage sump (m^3) and the pump flow rate in l/s for a pumped drainage system with a catchment area of $800m^2$. You may use the data in Table 1 below.

Table 1

| | | | | | | |
|---------------------|-------|-------|-------|-------|-------|-------|
| Duration (hrs) | 3 | 4 | 5 | 6 | 12 | 24 |
| Total Rainfall (mm) | 151.4 | 210.6 | 253.4 | 281.9 | 376.7 | 533.2 |

Question 3

- (a) What are the differences between a winch and a hoist?
- (b) Under what conditions can you use a winch for lifting?
- (c) You have to pull a load of 6,000kg. The load is not and cannot be mounted on wheels. The only winch you have at hand is one rated at 5,000kg. Suggest a method that you may use to effect the pull.

Question 4

Use the isometric design of an Ordinary Hazard Group II sprinkler system as shown in Figure Q4, to design according to the pre-calculated method.

- Determine the water supply requirements and show them on Figure Q4.
- Size all range points.
- Insert the Design Point.
- Size all distribution pipes downstream of the Design Point.
- Complete the Statement of Distribution Pipe Losses.

Submit the answer sheets provided with the rest of your answers in the answer book.

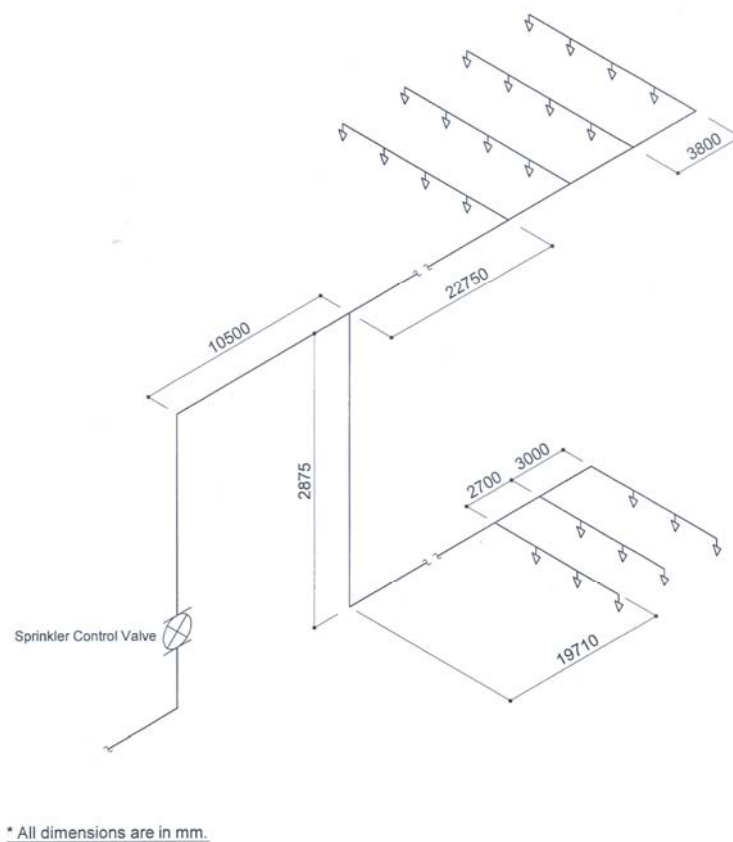

Figure Q4. Isometric design of an Ordinary Hazard Group II sprinkler system

Question 5

A pressure vessel consisting of a shell and two hemispherical heads is constructed from SA 516-70 carbon steel material (Tensile Strength – 70 ksi). The self-reinforced nozzles in the vessel are made from type SA 213-316 stainless steel material (Tensile Strength – 75 ksi). The vessel is shut down eight times a year for maintenance. At start-up, the full pressure of 300 psi and full temperature of 450°F are reached in two hours. The maximum ΔT between any two points during start-up is 300°F. At normal operation, the ΔT is negligible. At shutdown, the maximum ΔT is 100°F. Determine the maximum number of years that this vessel can be operated if a fatigue evaluation is not performed.

You may use the following information:

- (i) In accordance with ASME Boiler and Pressure Vessel Code, Section VIII Division 1, paragraph UG-22 or U-2(g), fatigue analysis is not required for materials with a tensile strength of less than 80 ksi when the total number of cycles in (a) through (d) below is less than 1000.
- (a) The design number of full range pressure cycles including startup and shutdown.
- (b) The number of pressure cycles in which the pressure fluctuation exceeds 20% of the design pressure.
- (c) Number of changes in metal temperature between two adjacent points. These changes are multiplied by a factor obtained from Table 2 in order to transform them to equivalent cycle number.

Table 2

| Metal Temperature Differential, °F | Factor |
|------------------------------------|--------|
| 50 or less | 0 |
| 51 to 100 | 1 |
| 101 to 150 | 2 |
| 151 to 250 | 4 |
| 251 to 350 | 8 |
| 351 to 450 | 12 |
| Higher than 450 | 20 |

- (d) Number of temperature cycles in components that have two different materials where a difference in the value $(\alpha_1 - \alpha_2) \times \Delta T$ exceeds 0.00034. Where, α is the coefficient of thermal expansion and ΔT is the difference in temperature.
- (ii) The coefficient of expansion for carbon steel is 6.5×10^{-6} in./in./°F and that for stainless steel is 9.5×10^{-6} in./in./°F.

Question 6

Figure Q6 below shows a single basement carpark, 60m x 30m, in area. Two void openings, each 10m x 4.5m, are provided at the 1st storey above the car park, and is open to the sky. Two opposite walls in the basement carpark are provided with 1.2m deep openings throughout the length of the wall, as shown.

- Calculate the mechanical ventilation requirements for the Basement Carpark.
- In what type of buildings would such carpark ventilation system be permitted?

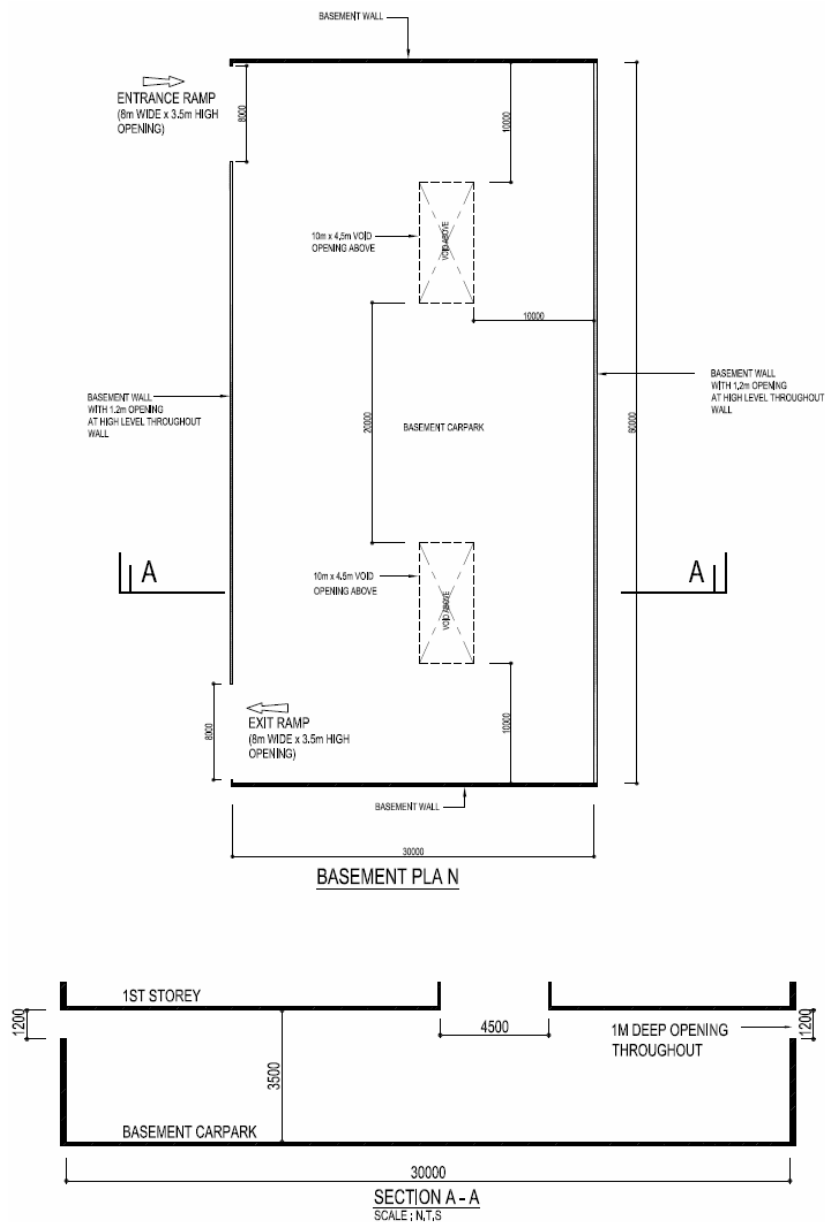

Figure Q6: Single basement carpark

Question 7

The design data from a chilled water plant are as follows:

| | |
|---------------------------------------|---------|
| Chiller cooling capacity | 1760 kW |
| Chiller COP | 7.0 |
| Chilled water supply temperature | 6.5 °C |
| Chilled water return temperature | 12.2 °C |
| Chilled water pump head | 300 kPa |
| Chilled water pump efficiency | 75 % |
| Chilled water pump motor efficiency | 92 % |
| Condenser water supply temperature | 29.5 °C |
| Condenser water return temperature | 35.0 °C |
| Condenser water pump head | 200 kPa |
| Condenser water pump efficiency | 75 % |
| Condenser water pump motor efficiency | 92 % |
| Cooling Tower fan power | 35 kW |

- (a) Calculate the volume flow rates for chilled and condenser water. Do the pumps meet the power limitation requirements of the code? Suggest a remedy if the conditions are not met.

Show that by the use of variable speed pumping control the pumps will be able to meet the part load performance requirements of the code. Water density and specific heat may be assumed to be 1000 kg/m³ and 4.18 kJ/kg·K, respectively.

- (b) What is the overall energy efficiency ratio (EER) of the cooling plant expressed as kW of electric power consumed per kW of cooling?

V Practice of Professional Engineering Examination Part 2 (Chemical)

The paper aims to examine the candidates' proficiency in the practice of chemical engineering at a professional level. Candidates are expected to have a good working knowledge and experience in process safety, process design & operations and related chemical engineering practices in Singapore.

Candidates are also expected to have a good understanding and knowledge of regulatory framework, including safety case regime, statutory acts & regulations and legislative requirements on chemical safety management, fire safety and environmental pollution control.

The examination will place emphasis on the Professional Engineers' roles in the practical application of standards, codes of practice, technical guidance, recommended practices relevant to the chemical & process industries and chemical engineering works to support the industries.

Format

This is a 4 hours 10 mins paper that examines candidates on technical competency and understanding of the use and application of legislation, standards and codes that are relevant to the practice of chemical engineering at a professional level in Singapore.

The paper consists of 2 sections comprising a total of 8 questions. Candidates are required to answer questions in both sections (Section 1 and Section 2). Section 1 will consist of a compulsory question on principles, process safety management, general chemical engineering practices, codes & standards and legislations, including safety case, environmental protection and management. Section 2 will consist of 7 optional questions. Candidates may choose to answer any 4 out of the 7 questions.

Syllabus

The scope of professional engineering work covered by Professional Engineers (Chemical) may include the following fields: -

- **Plant & Process Design**

Process Design; Process Equipment Design; Plot Plan / Equipment Siting; Instrumentation & Control Schemes; Materials of Construction (material properties and selection, corrosion considerations Etc.); Equipment Design Life.

-
- **Process Safety Management (PSM)**
Process Safety Management Elements; Process Safety Performance Indicators (CCPS Process Safety Leading and Lagging Metrics); WSH Guidelines on Process Safety Performance Indicators; OSHA 1910.119 Process Safety management of highly hazardous chemicals; Singapore Standard SS 651:2019 Safety and Health Management System for the Chemical Industry; API RP 754 for Process Safety Performance Indicators for the Refining and Petrochemical Industries.
 - **Process Hazard Analysis**
Hazard Identifications and Evaluation Techniques [What-If / HAZOP Terminology and Methodology / Failure Mode Effect Analysis (FEMA)]; Logic Tree - Fault Tree Analysis; Bow-Tie Concept.
 - **Functional Safety SIL Classification and Verification**
Functional Safety (IEC 61508 / IEC 61511 / SIS Safety Life Cycle); Basic Process Control System to HIPS/SIS, SIF, SIL; from HAZOP to Layer of Protection (LOPA); Estimating Consequences & Risk Tolerant Criteria; Failure Types; Hardware Fault Tolerance and Redundancy; Common Cause Failures – β factor; calculating Probability of Failure on Demand.
 - **Fundamental of Hazardous Area Zone Classification**
Standards for Hazardous Area Zone Classification [IEC System; American System (NEC)]; Principles of Hazardous Area Zone Classification; Explosive Dusts Classification; Material Classification; Temperature Classification; Explosion Protection Type for Electrical Equipment; Equipment Protection Level (EPL) Symbols.
 - **Chemical Runaway Reactions and Auto-refrigeration**
Characteristics of Chemical Runaway Reactions; Hazard Assessment of Chemical Reactions; Selecting and Specifying a Basis of Safety [Factors to be Considered / Preventive Measures (Temperature; Addition; Agitation; Scrubber System / Vents; Safe Time; Instrumentation & Control) / Protective Measures (Emergency Relief System; Inhibiting Runaway Reaction; Quenching & Dumping; Containment)]; Inherent Safer Design (Minimize; Substitute; Moderate / Attenuate; Simplify / Limit Effects – Plant Layout & Equipment Spacing); Auto-refrigeration, controls and materials selection.
 - **Pressure Relief System**
Overpressure Scenarios and Identification; Pressure Relief Valve Type; Effects of Backpressure on Pressure Relief Valve; Pressure Relief Valve Selection; Rupture Disk Devices and Application; ASME Boiler & Pressure

Vessel Code Section VIII Requirements [References: Sizing Pressure Relief Valve Back to Basic; API 520 Sizing, Selection, and Installation of Pressure-relieving Devices in Refineries Part I – Sizing and Selection; API 521 Pressure-relieving and Depressuring Systems; Safety Blowdown and Flare system.

- **Safe Plant Operations**

Common Hazards Associated with Process Plant to Avoid; Start-up Preparation & Procedures (Elimination of Air / Tightness Testing / Elimination of Water Etc.); Shut Down for Maintenance (De-inventory / Hydrocarbon Freeing / Positive Isolations Etc.); Dust Explosion; Electrical Safety; Management of Change (MOC); Pre-Start-up Safety Review (PSSR); Standard Operating Procedures (SOP); Static-Electricity, Pyrophoric Materials; Auto-ignitions plus control measures; Confined Space safe entry requirements.

- **Quantitative Risk Analysis**

Consequences estimation for fire, explosion [TNO multi-energy model] and gas dispersion; Source term calculations; Event Tree Analysis; Common Preventive and Mitigation Measures to Reduce the Failure Frequencies; Concept of risk calculations [Individual Risk (IR), Location Specific Individual Risk (LSIR), Potential Loss of Life (PLL)] and Risk Criteria.

- **Safety Case**

Concept of safety case; Identification of major accident hazards; Determination of major accident scenarios and safety critical events; Barrier and mitigation measures; ALARP demonstration.

- **Energy Conservation for Chemical, Process & Utilities Plants**

Environmental Consideration (Emissions Evaluation and Permitting; Pollution Prevention and Mitigation; Waste Determination and Management); Energy Efficiency Assessment, Evaluation and Mitigation Measures for Carbon Emission Reduction; Process Optimization including Optimal Energy Consumption.

- **Relevant Legislation, Standards, Codes of Practices, Guidelines (Based on latest applicable Legislation, Standards, Codes, Guidelines)**

- **Legislation**

- Workplace Safety and Health Act

- Workplace Safety and Health (Major Hazard Installations) Regulations
 - Workplace Safety and Health (General Provisions) Regulations
 - Environment Protection and Management Act
 - Fire Safety Act
 - Gas Act
- **Standards and Code of Practices**
- Singapore Standard CP 75 – Code of Practice for Gas Cylinders – Procedures for change of gas services
 - Singapore Standard SS 532 – Code of Practice for the storage of flammable liquids
 - Singapore Standard SS 537 – Code of Practice for the Safe Use of Machinery
 - Singapore Standard SS 568 – Code of Practice for Confined Spaces
 - Singapore Standard SS 586 – Specification for hazard communication for hazardous chemicals and dangerous goods
 - Singapore Standard SS 634 – Fire Safety for Open Plant Processing Facilities in Oil, Chemical and Process Industries
 - Singapore Standard SS 639 – Code of Practice for the filling, inspection, testing and maintenance of gas cylinders for the storage and transport of compressed gases
 - Singapore Standard SS 651 – Safety and Health Management System for the Chemical Industry
 - Singapore Standard SS 667– Code of Practice for handling, storage and processing of combustible dust
 - IP 15 – Hazardous Area Classification Guide
 - IEC 61508 – Functional Safety of electrical/electronic/programmable electronic safety-related systems

- IEC 61511 – Functional Safety – Safety Instrumented Systems for the process industry sector
 - API RP 505 – Recommended Practice of Classification of Location for Electrical Installations at Petroleum Facilities classified as Class 1, Zone 0, Zone 1 and Zone 2
 - API RP 520 Part 1 & 2 - Sizing, Selection, and Installation of Pressure-Relieving Devices in Refineries
 - API RP 521 - Guide for Pressure-Relieving and – Depressuring Systems
 - API 580 - Risk-based Inspection
 - API 610 - Centrifugal Pumps for Petroleum, Heavy Duty Chemical and Gas Industry Services
 - API 617 - Centrifugal Compressor for Petroleum, Chemical and Gas Service Industries
 - API 618 - Reciprocating Compressors for Petroleum, Chemical and Gas Industry Services
 - API 619 - Rotary type Positive Displacement Compressors for Petroleum, Chemical, and Gas Industry Services
 - API 650 - Welded Tanks for Oil Storage
 - API RP 751- Recommended Practice for Safe Operation of Hydrofluoric Acid Alkylation Units
 - API RP 754 – Recommended Process Safety Performance Indicators for the Refining and Petrochemical Industries
 - API RP 2003 - Protection Against Ignitions Arising Out of Static, Lightning, and Stray Currents
 - API RP 2219 – Safe Operation of Vacuum Trucks in Petroleum Service
- **Guidelines**
- Safety Case Technical Guide
 - Safety Case Assessment Guide
 - ALARP Demonstration Guidelines: Single Scenario Risk Tolerability and Adequacy of Barriers

- Guidelines on Safety Instrumented Systems in Major Hazards Installations
- Guidelines on managing human factors in Major Hazards Installations
- QRA Criteria Guidelines
- QRA Technical Guidance
- WSH Guidelines – Process Safety Performance Indicators

Sample Questions for Practice of Professional Engineering Examination Part 2 (Chemical)

Section 1 – Question 1 (28 marks) is COMPULSORY

Question 1

- (a) In a Safety Case regime, Major Hazard Installations (MHIs) are required to manage the risk of possible major accident scenarios, especially safety critical events, based on a tolerability of risk framework. Typical criteria for the boundaries of tolerability of risk framework are shown in the figure below:

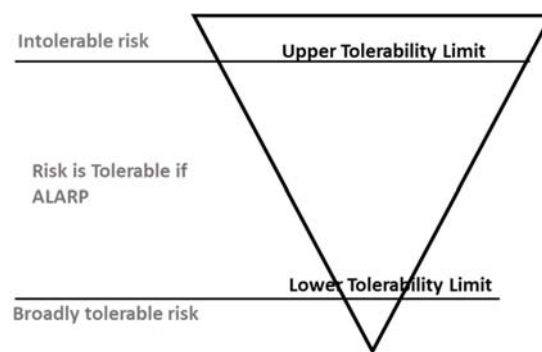

- (i) What do you understand by the term "ALARP"?
- (ii) Explain the demonstration required if risk is within the "Risk is tolerable if ALARP" region.
- (b) It is essential for Major Hazard Installations to identify all major accident hazards, their likelihood and consequences before going on to perform a sufficient and suitable risk assessment and identify risk reduction measures in the safety case.
- (i) Define major accident hazards.
- (ii) Explain how to derive a set of safety critical events from a list of major accident scenarios.
- (iii) Explain the principle of proportionality.
- (c) In a Safety Case, explain how a Major Hazard Installation demonstrates that adequate control measures have been provided to protect its plant against excursions beyond design conditions.

Section 2 – Answer 4 Out 7 Questions (each at 18 marks)

Question 2

An instrument is to be used in a Safety Instrumented Function (SIF) in a low demand mode application. The failure rates are given as:

Lambda S (λ_S): 12.5×10^{-7} failures per hour

Lambda DD (λ_{DD}): 2.5×10^{-7} failures per hour

Lambda DU (λ_{DU}): 5.0×10^{-7} failures per hour

- (a) Calculate the Safe Failure Fraction (SFF) of this instrument.
- (b) Supposed this is a Type B component in single configuration. What is the maximum SIL of the application where this device may be used in low demand mode, based on IEC61511? Explain your answer.

Question 3

Anhydrous Ammonia has the following GHS classification:

| | |
|--------------------------------------|-------------|
| Flammable gases | Category 2 |
| Acute toxicity (inhalation) | Category 3 |
| Skin corrosion/irritation | Category 1B |
| Serious eye damage/eye irritation | Category 1 |
| Hazardous to the aquatic environment | Category 1 |

A pressure vessel 4m in height and 2m in diameter contains anhydrous ammonia. A pressure transmitted installed on the vessel shows a reading of 10 barg. Temperature of the vessel is 30degC. A 10mm diameter hole occurs in the vessel at around 2m height during operation.

- (a) Compute the release rate of anhydrous ammonia to the environment.
- (b) Given that the failure frequency of a 10mm leak for a pressure vessel is 6.8×10^{-6} /year, determine the frequencies of all potential hazard outcomes associated with the release of anhydrous ammonia from the vessel. Justify any assumptions used.
- (c) Determine the concentration of anhydrous ammonia at a residential area 500m away from the release. Assume atmospheric stability class F.

Question 4

Process and equipment integrity and reliability are keys to ensure facility process safety.

- (a) What are the inspection, testing and maintenance requirement of an instrument air receiver?
- (b) Describe briefly what to look out for in starting up a steam boiler. What actions do you take to re-start a boiler after an emergency trip / shutdown?
- (c) In a process without standby generator, what should you provide for the safe operations / safe shut down of the process plant in the event of main power failure or interruption?

Question 5

- (a) Describe briefly the areas of concern in environmental protection and pollution control.
- (b) Energy conservation is one of the key concerns today, to reduce carbon emission. What are operating efforts that could be taken to reduce energy usage?
- (c) In industry, the large energy users are fired heaters such as steam boilers and industry furnaces. How you optimise a fired heater to reduce carbon emission?

Question 6

Pressure Relief Valves (PRVs) are installed to protect process equipment from overpressure. A spherical tank 18m in diameter is installed in a tank farm with the Bottom Tangent Line (BTL) of the tank held at 1.5m from ground level. The tank is designed to store liquid n-butane (C_4H_{10}), with a design pressure (DP) of 8 barg. A PRV shall be provided on top of the tank for safety relief during fire exposure and the tank is not insulated.

Refer to API 520 and API 521 to complete the question.

- (a) What are the 3 main types of pressure relief valves normally used in the petrochemical/chemical industry? Describe the circumstances under each type is used.
- (b) Determine the relieving vapour load (kg/h) to the PRV during a fire contingency.

- (c) Select the PRV type and calculate the orifice size (sq. mm) required of the PRV for the fire contingency.

Question 7

In process design of an equipment, the Design Temperature (DT) and Design Pressure (DP) are usually specified.

- (i) What are reasons for doing so? Give reasons for each.
- (ii) If the maximum operating temperature of equipment is 300 deg.C and maximum operating pressure is 20 barg, how would you specify the DT and DP? Give your values.
- (iii) If a piece of equipment goes through a batch chilling process with temperatures cycling between freezing levels (say, -ve 20 degC) and ambient temperature, what is the hazard that this piece equipment could encounter? How is hazard usually overcome in the chemical industry?